

## AP250FP Gear Pumps

Flexible pump for dealers

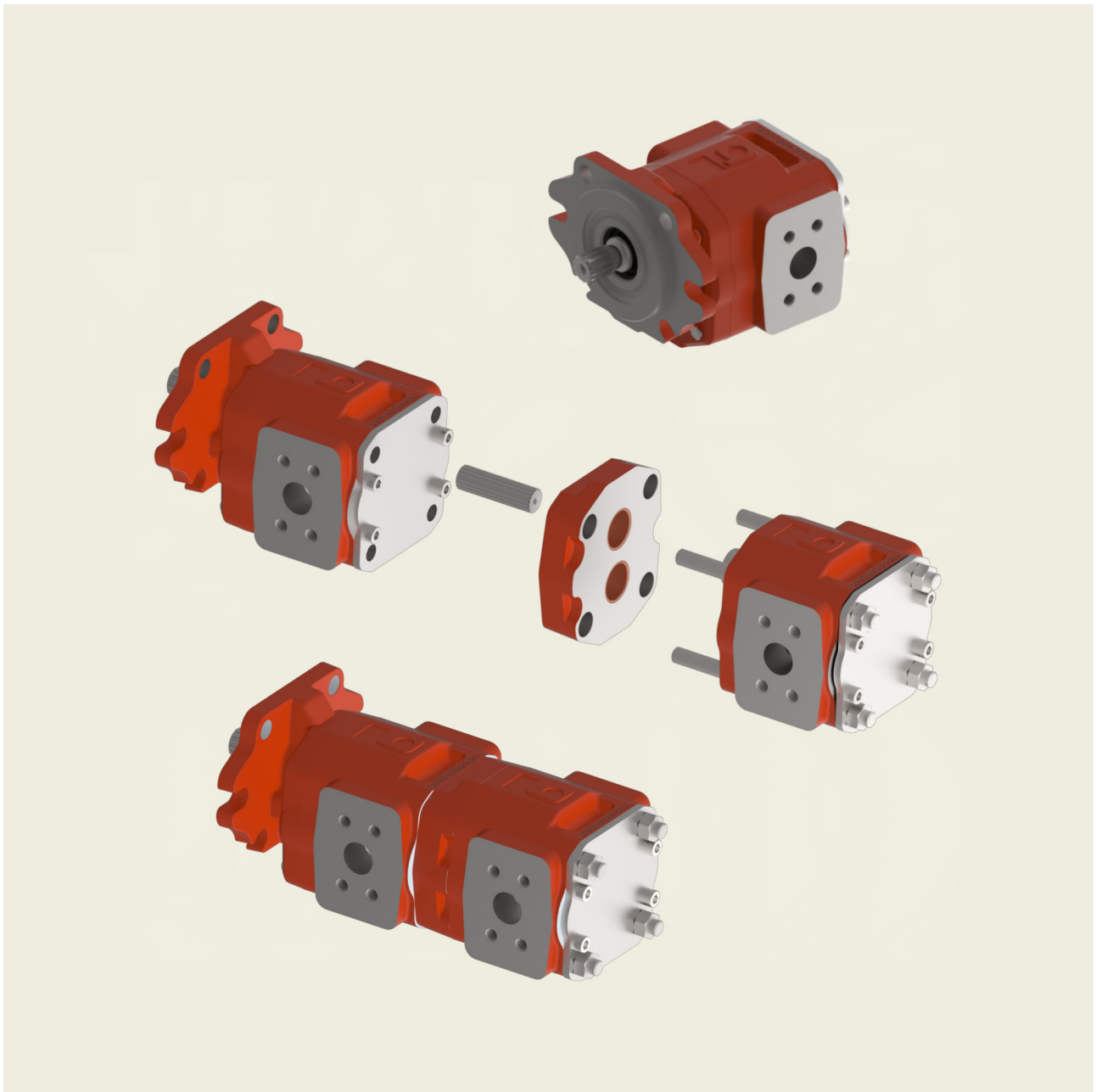

### Contents

Page

<b>1</b>	<b>General information</b> .....	<b>3</b>
1.1	External gear pumps components and construction / benefits .....	4
1.2	Technical data .....	5
1.3	Pressure .....	6
1.4	Suction .....	6
1.5	General precaution .....	6
1.6	Identifying the rotation direction .....	7
1.7	Formulas to determinate main gear pump operate parameters .....	8
<b>2</b>	<b>Overview standard pump configurations</b> .....	<b>9</b>
2.1	Standard components configuration .....	9
<b>3</b>	<b>Rotation changing instructions AP250FP</b> .....	<b>14</b>
<b>4</b>	<b>Multiple gear pumps</b> .....	<b>15</b>
4.1	Drive torque calculation .....	15
4.2	Multiple version: AP250FP+AP250FP (or AP250HP) .....	17
4.3	Tandem AP250FP+AP250FP (without shaf seal) .....	18
4.4	Middle pumps AP250FP-MP dimensions and ordering codes .....	19
4.5	Multiple versions: AP250FP+AP212-MPS (or AP212HP-MPS) .....	22
4.6	Tandem AP250FP+AP212 or AP212HP (with shaf seal) .....	23
4.7	Mid pump AP212-MPS: dimensions and ordering codes .....	24
4.8	Bolts .....	28
4.9	Back covers .....	28
4.10	Rotation changing instructions AP212 .....	31
4.11	Warnings .....	32
<b>5</b>	<b>Pumps seal kit NBR standard type</b> .....	<b>33</b>

## 1 General information

The product range of Bucher Hydraulics SpA includes single pumps 05-100-212-212HP-250HP-312HP (corresponding with the common group denominations: 05-1-2-2.5-3) and several combinations of double pumps, triple pumps, and so on, that can be assembled together according to versions of displacement, flanging, and auxiliary valves .

Bucher Hydraulics SpA has supplied a wide range of external gear pumps and motors to industrial and mobile applications since many years.

Bucher's external gear pumps are widely used in modern hydraulic system to obtain high performances, long life service and low purchase and maintenance costs.

Now, Bucher is introducing a new Gear Pumps family, AP250FP (group 2.5), specifically developed for dealers market.

Bucher designed this new pump AP250FP with support bearings mounted in the cast iron body and covers. Tandem and triple pumps are also available with direct connections between the shafts.

AP250FP is the result of a focused design, studied also with the aid of a software internally developed and used for the calculations of the most important mechanical parameters of the gears and to optimize all the performances with a consequent noise and vibration reduction.

Bucher Hydraulics has so achieved this state of the art by constantly improving its design, control and manufacturing techniques aligned with the latest technological developments, while simultaneously enhancing its Quality System ensuring that every single product offers the same high standards.

### Main applications and benefits

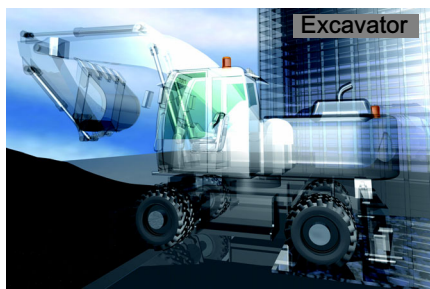

- Long life expectancy
- High efficiencies
- Noise & vibration reduction
- Strong interface
- Shaft load reduction
- AP250FP flange interface
- High pressure limits
- Reduced number of components
- Reduced overall dimension
- Direct and stronger connections between shafts (tandem/Triple pumps )
- Possibility to create multiple pumps even in a second times by the dealer.

## 1.1 External gear pumps components and construction / benefits

**A**

Cast iron front cover: the standard front-cover design can be fitted to different pump interfaces.

**B**

Cast iron main pump body: wide range of displacements obtainable with two different basic bodies.

**C**

HNBR seal material instead of NBR.

**D**

Double HNBR shaft seals.

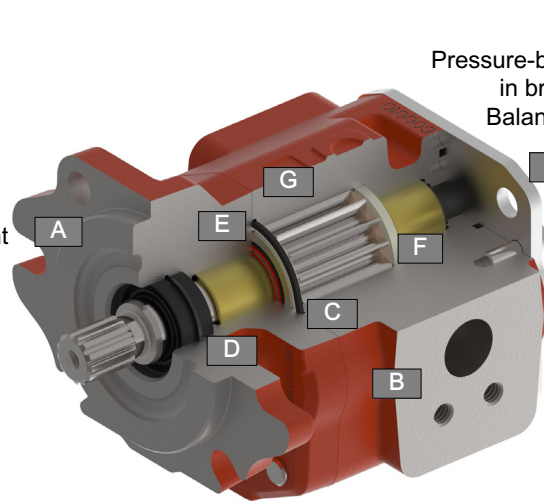

**E**  
Pressure-balance plate manufactured in bronze instead of aluminium. Balancing area and intermediate notches optimised.

**F**

Large-diameter bearings, fitted both in front cover and body.

**G**

Large number of teeth, tooth profile optimised, larger shaft diameter.

**H**

Removable rear plate

### BENEFITS

**A B** Flexibility/smaller number of components

**A D** Reduced risk of external leakage

**A B E** High efficiencies/pressure limits

**A B E** Long life expectancy

**C D** Wider temperature range

**E G** Lower pressure ripple

**E G** Noise/vibration reduction

**E F G** Higher load capacity and transmissible torque

**E F G** Low friction and high mechanical efficiency

**E F G** Higher max. pressure limit

**H** Possible multiple pumps created by dealer

The front mounting flange and the body are made of high-strength cast iron to give thermal stability, resistance to contamination and the strength necessary for persistently high levels of performance and life, needed in demanding heavy duty applications. Cast iron body and flange, bigger shaft diameter, bigger bearing dimension and bronze

trust plate have been optimized to provide heavy duty, high pressure limits, high efficiencies and long life expectancy. Noise and vibration reduction due to the high number of teeth.

The bearings are located in the front mounting flange, in the body and, for multiple pumps, in the intermediate cover.

## 1.2 Technical data

Features		
Displacements	26 - 54 cm <sup>3</sup> /rev (63-75-86 to be defined)-	
Maximum continuous pressure	300 bar (depending on displacement)	
Fluid temperature range	-20 / +90 °C (Extreme condition temperature range: -30 +110 °C)*	
Recommended fluids	hydraulic mineral oil-based	
Viscosity range:	Recommended Permitted (not continuous) Permitted for starting	20-120 mm <sup>2</sup> /s (cSt) up to 700 mm <sup>2</sup> /s (cSt) 2000 mm <sup>2</sup> /s (cSt)
Contamination class:	working pressure > 210 bar working pressure < 210 bar	19/17/14 ISO 4406 20/18/15 ISO 4406
		8 NAS1638 9 NAS 1638
Standard seals material	HNBR standard	

\* Extreme working temperature limits values can not be combined

Size	Displacement		Pressure				Min speed rpm	Max speed** rpm
	cm <sup>3</sup> /rev	Cu.In.P.R.	P1		P3			
			bar	P.S.I.	bar	P.S.I.		
26	26.4	1.611	300	4350	320	4640	500	3500
33	33.2	2.026	300	4350	320	4640	500	3500
40	40.5	2.471	300	4350	320	4640	500	3500
45	45.3	2.764	280	4060	310	4500	500	3500
54	54	3.295	240	3480	270	3900	500	3000
63***	63.2	3.856	-	-	-	-	-	-
75***	74.9	4.571	-	-	-	-	-	-
86***	86.5	5.278	-	-	-	-	-	-

\*\* : The max admitted speed is referred to single pump/single inlet configuration. In case of multiple pumps with common suction line, a speed reduction must be considered.

\*\*\* : 63-75-86 displacement under test-phase



**IMPORTANT!:** The pressure values are referred to unidirectional pumps, single versions only.

Please consult Bucher Hydraulics if even one of the operating limits indicated in the table (temperature, pressure, rpm) is exceeded, as well as in the case of two or more maximum values at the same time, or for applications with particularly heavy-duty cycles

## 1.3 Pressure

Pressure levels:

P1 = continuous pressure

P3 = peak pressure

The recommended oil speed in the pressure pipes is:

$v = 2$  to  $5$  m/s

## 1.4 Suction

The absolute suction pressure must be  $P_{in} \geq 0.75$  bar (11 PSI); therefore, the following must be avoided:

- large height differences between pump and tank
- long stretches of piping
- special features such as:
  - bends
  - reductions in diameter
  - quick couplings
  - etc.

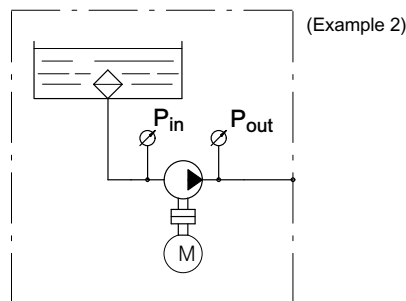
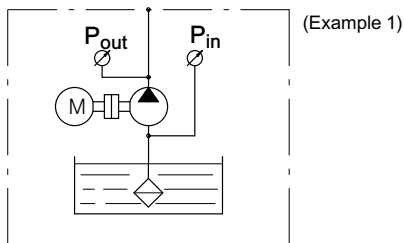

## 1.5 General precaution

In addition to the recommendations regarding fluids, filtration, coupling, etc., we suggest the following:

- Always check the rotation direction of the pump's drive shaft; it must be compatible with the rotation direction of the pump itself.
- Be particularly careful in cleaning and make sure, when connecting the suction and pressure piping, that no chips, rag threads, teflon tape, etc. get into the pump circulation system.
- Check the tightness of the suction and pressure fittings, the correct positioning of the O-Ring, and make sure there is no dirt between the flange and the pump body.
- The first pump start-up can be facilitated by manually filling the suction piping and the pump itself with oil. To facilitate air bleeding, start the pump with the circuit not pressurised.

### 1.5.1 Hydraulic fluid

The main function of the fluid used in hydraulic systems is to transfer energy but it performs also other important functions: protect the components from corrosion, lubricate the pump moving parts, remove particles and heat from the system.

In order to ensure proper operation and long life of the system it is important to choose the correct hydraulic fluid with proper additives.

Bucher Hydraulics recommends to use a mineral based oil responding to ISO 6743/4 requirements, only.

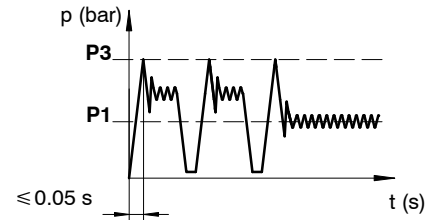

It is also advisable to choose a filter of a suitable size to minimise any pressure drop and to take measures to prevent gradual clogging over time.

- To ensure the best heat distribution inside the tank, make sure the return pipe is not too close to the pump's suction piping. The pipings themselves should be below oil tank level to prevent the formation of foam.
- Do not subject the pumps to operating conditions different from those indicated on section 1.2 ; for extreme operations, always contact our Sales Department.
- In the event of pump painting, do not use solvents or paints that are incompatible with the material of the seals. Do not bake paint with excessively high temperatures. Do not paint over the product identification plate.

The system should be operated only with hydraulic oil containing anti-foaming and antioxidant additives. Before using other types of fluid, please contact our Sales Dept, since they can cause serious damage to the directional valve components and jeopardize the correct function of the system.

Never use fluids different from those indicated in section 1.2 and do not use fluids incompatible with the pump seals (i.e. HNBR)

## 1.5.2 Filtration

In order to ensure proper operation and long life of the pump components it is extremely important to provide a proper and effective filtration of the hydraulic fluid.

It is advisable to follow filter manufacturers instruction and recommendations.

The fineness of the filter should be selected in order to guarantee that a contamination levels indicated on section 1.2. When the high reliability of the system is an important requirement, a pressure filter must be used. In these cases it is also advisable to use a pressure filter with by-pass and indicator.

The size of the return filters must suit the maximum return

flow whereas the size of the pressure filters must suit the maximum pump flow.

It is advisable to fit filters with pressure gauge or dirt indicator in order to make it possible to verify the filter condition. Particular attention has to be paid to the cleaning of the machine hydraulic circuit and its components before the first run-in, since the presence of foreign materials could cause damages even if a proper filtration is provided.

In order to obtain the best performance of the system we recommend to strictly follow the conditions advised here above, failing which warranty shall be void.

## 1.5.3 Directives and standards

Atex



Attention: The equipment and protective systems of this catalogue ARE NOT intended for use in potentially explosive atmospheres that is to say where there is an explosive atmosphere. Ref: Directive 99/92/EC and Directive 2014/34/UE.

- ISO 9001:2015 / ISO 14001:2015 / ISO 50001:2018

Bucher Hydraulics S.p.A. is certified for research, development and production of directional control valves, gear pumps and motors, power units, electro pumps, cart-ridge valves and integrated manifolds for hydraulic applications.

## 1.6 Identifying the rotation direction

The rotation direction of a gear pump is identified by looking at the pump from the front and with the drive gear turned upwards (see figures below).

Pumps with clockwise rotation (D) have a drive gear which turns clockwise, with the suction port on the left and the pressure port on the right.

Pumps with counterclockwise rotation (S) have a drive gear which turns counterclockwise, with the suction port on the right and the pressure port on the left.

right and the pressure port on the left. The figure also shows the pressure flow inside the pumps as the oil is transferred from the suction port to the pressure port.

Pumps with a unidirectional rotation (D or S) have the denomination AP.

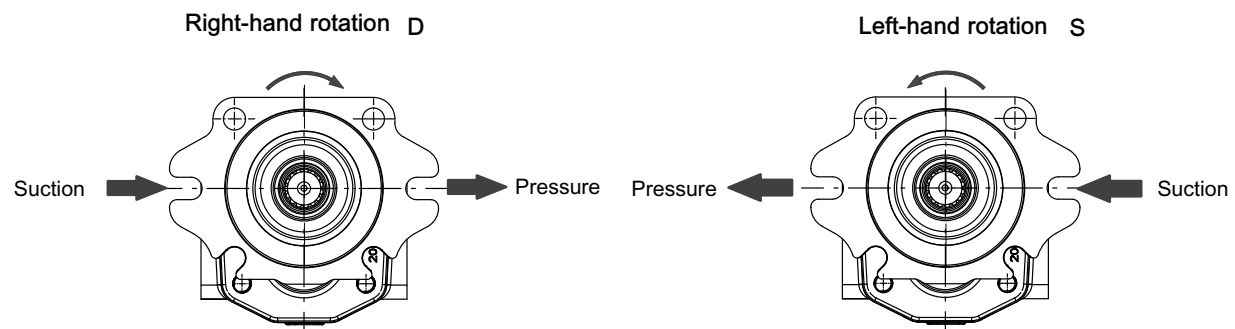

### 1.7 Formulas to determinate main gear pump operate parameters

The following parameters are defined:

$V_c$  = (cm<sup>3</sup>/rev) pump displacement;

$n$  = (rev/min) no. of rpms of the drive shaft;

$Q$  = (l/min) flow rate;

$p$  = (bar) operating pressure;

$T$  = (Nm) drive torque;

$N$  = (kW) Absorbed power;

$\eta_v$  = (%) volumetric efficiency;

$\eta_m$  = (%) mechanical efficiency;

$\eta_t$  = (%) total efficiency

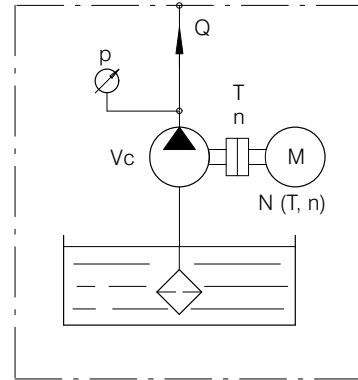

$$Q = \frac{V_c \cdot n}{100000} \cdot \eta_v \quad T = 1.59 \cdot \frac{p \cdot V_c}{\eta_m} \quad N = \frac{Q \cdot p}{6 \cdot \eta_t}$$

#### Example

AP250FP/26  $V_c = 26.2 \text{ cm}^3/\text{r}$   $n = 1500 \text{ r/min}$   $p = 200 \text{ bar}$   $\eta_v = 94\%$   $\eta_m = 90\%$   $\eta_t = 84.6\%$

$$Q = \frac{26.2 \cdot 1500}{100000} \cdot 94 = 36.94 \text{ l/min.} \quad T = 1.59 \cdot \frac{200 \cdot 26.2}{90} = 92.57 \text{ Nm} \quad N = \frac{36.94 \cdot 200}{6 \cdot 84.6} = 14.55 \text{ kW}$$

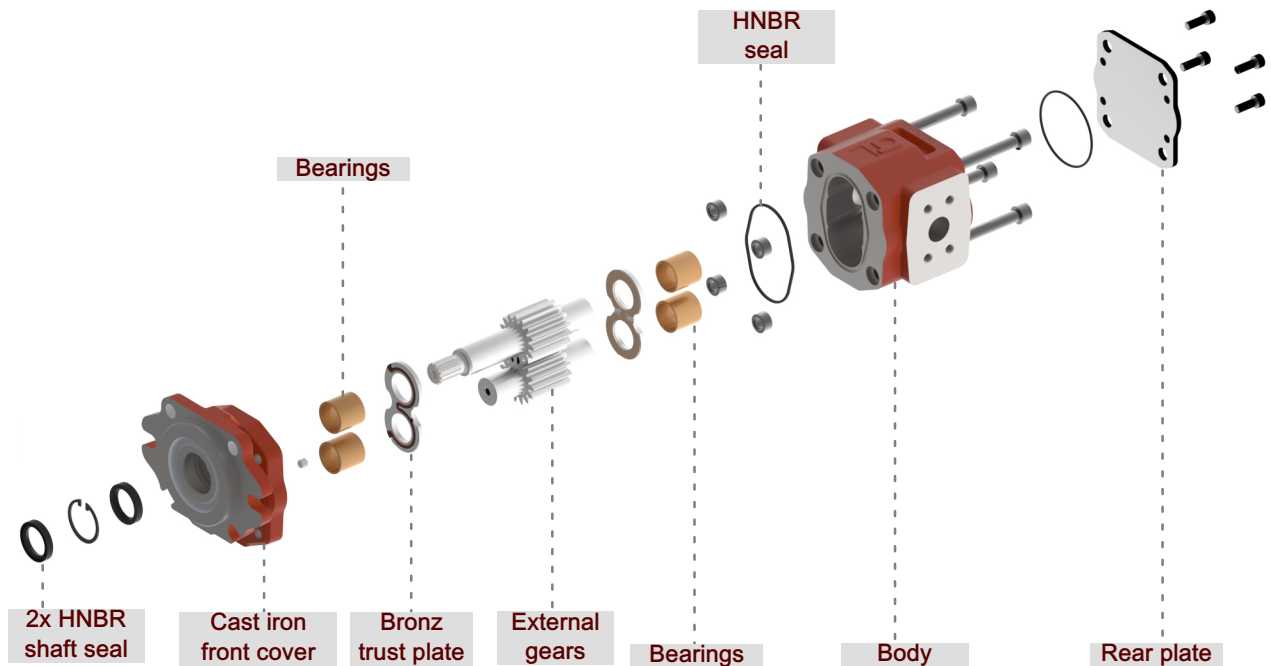



## 2 Overview standard pump configurations

This pumps configuration example are considered as "standard".

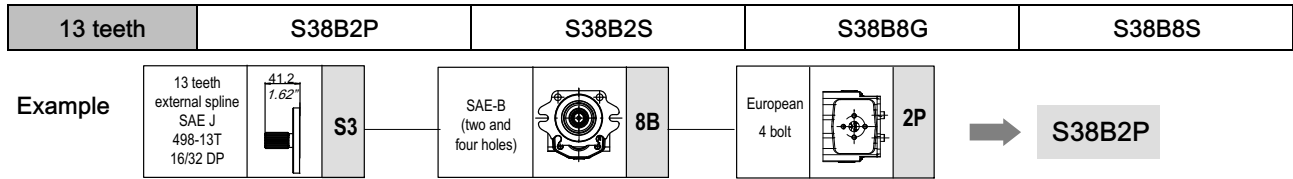



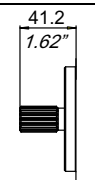
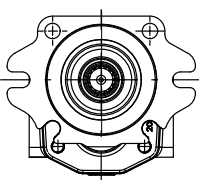
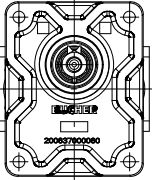
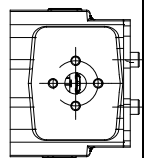
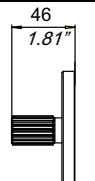
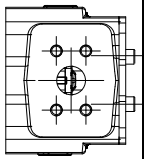
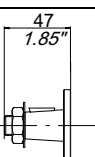
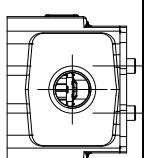

In the next pages, front, body/rear cover, and seals materials are listed for each pump series. For ordering purposes, it is enough to outline the complete pump description (for example: AP250FP/15 S38B2P).

In case of a different configuration request (or a combination of different features, such as port threads, front flange materials, etc.), the description configurator shown in section 3.1 can be easily used.

### 2.1 Standard components configuration

Drive shaft			Cast iron flange			Cast iron body/back cover Port type		
13 teeth external spline SAE J 498-13T 16/32 DP $T_{max} = 270 \text{ Nm}$  <b>S3</b>	SAE-B (two and four holes - $\varnothing 101.6 \text{ mm} - 4" \text{ inches}$ )  European rectangular ( $\varnothing 50.8 \text{ mm} - 2" \text{ inches}$ )	  	European 4 bolts flanged  <b>2P</b>					
15 teeth external spline SAE J 498-15T 16/32 DP $T_{max} = 460 \text{ Nm}$  <b>S5</b>			SAE FLANGED PORTS J518 (3000 PSI series)  <b>2S</b>					
Tapered 1:8 $T_{max} = 250 \text{ Nm}$  <b>C8</b>			BSP Ports  <b>8G</b>					

Serie	page	Serie	page	Serie	page	Serie	page
S38B2S - S58B2S	10	S38B8G - S58B8G	11	C81P8G	12	C81P2P	13
							

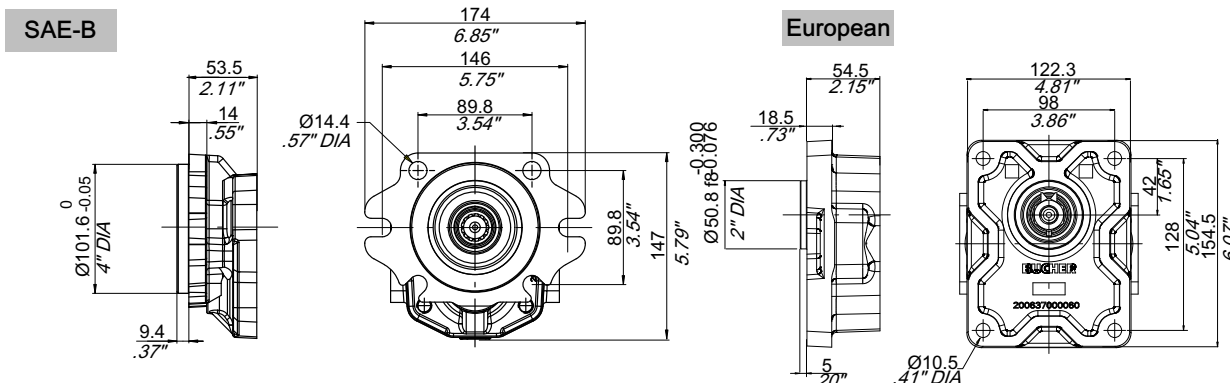

## 2.1.1 SAEB front flange, 13 or 15 teeth, SAE flanged ports

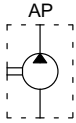

S38B2S  
S58B2S

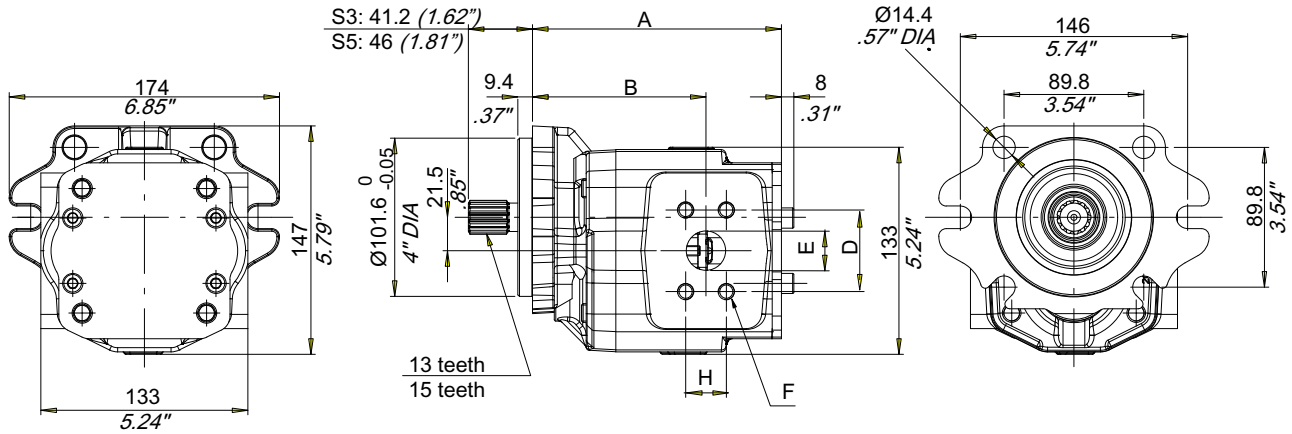
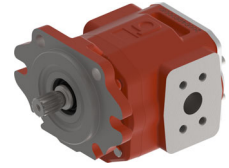

Size	A		B		Suction						Pressure							
	mm	inches	mm	inches	H		D		E		F	H		D		E		F
					mm	inch.	mm	inch.	mm	inch.	mm	mm	mm	inch.	mm	inch.	mm	mm
26	140.5	5.53	97	3.82	30.17	1.19	58.72	2.31	31.8	1.25	M10x 1.5	26.19	1.03	52.37	2.06	25.4	1	M10x 1.5
33	147.5	5.81	104	4.09														
40	155	6.10	106.5	4.19														
45	160	6.30	111.5	4.39														
54	169	6.65	120.5	4.74	35.71	1.14	69.85	2.75	38.1	1.5	M12x 1.75	30.17	1.19	58.72	2.31	31.8	1.25	M10x 1.5
63	180.2	7.09	98.5	3.88														
75	192.2	7.57	110.5	4.35														
86	192.2	7.57	110.5	4.35														

63-75-86 displacement under test-phase

Pump description example:

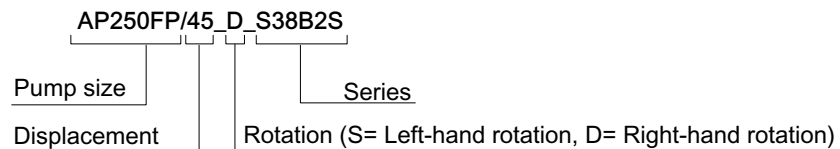

## 2.1.2 SAEB front flange, 13 or 15 teeth, BSP threaded ports

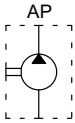

S38B8G  
S58B8G

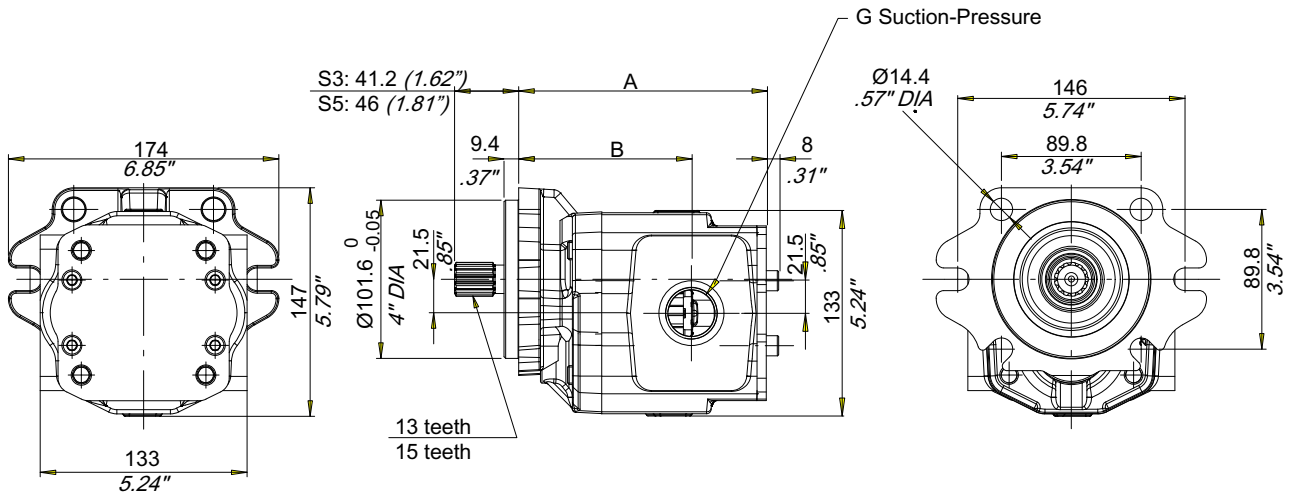
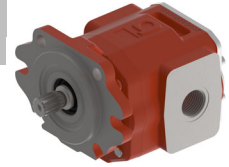

Size	A		B		Suction BSPP	Pressure BSPP
	mm	inches	mm	inches		
26	140.5	5.53	98	3.82	1"	3/4"
33	147.5	5.81	104	4.09		
40	155	6.10	106.5	4.19	1" 1/4"	1"
45	160	6.30	111.5	4.39		
54	169	6.65	120.5	4.74		
63	180.2	7.09	98.5	3.88		
75	192.2	7.57	110.5	4.35		
86	192.2	7.57	110.5	4.35		

63-75-86 displacement under test-phase

Pump description example:

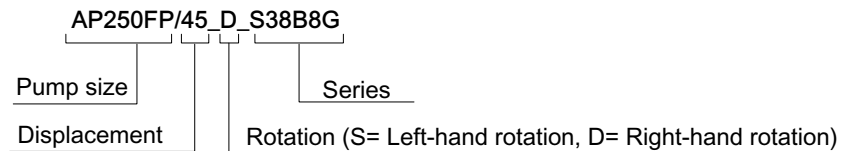

## 2.1.3 European front flange, tapered 1:8, European 4 bolt flanged ports (plessey ports)

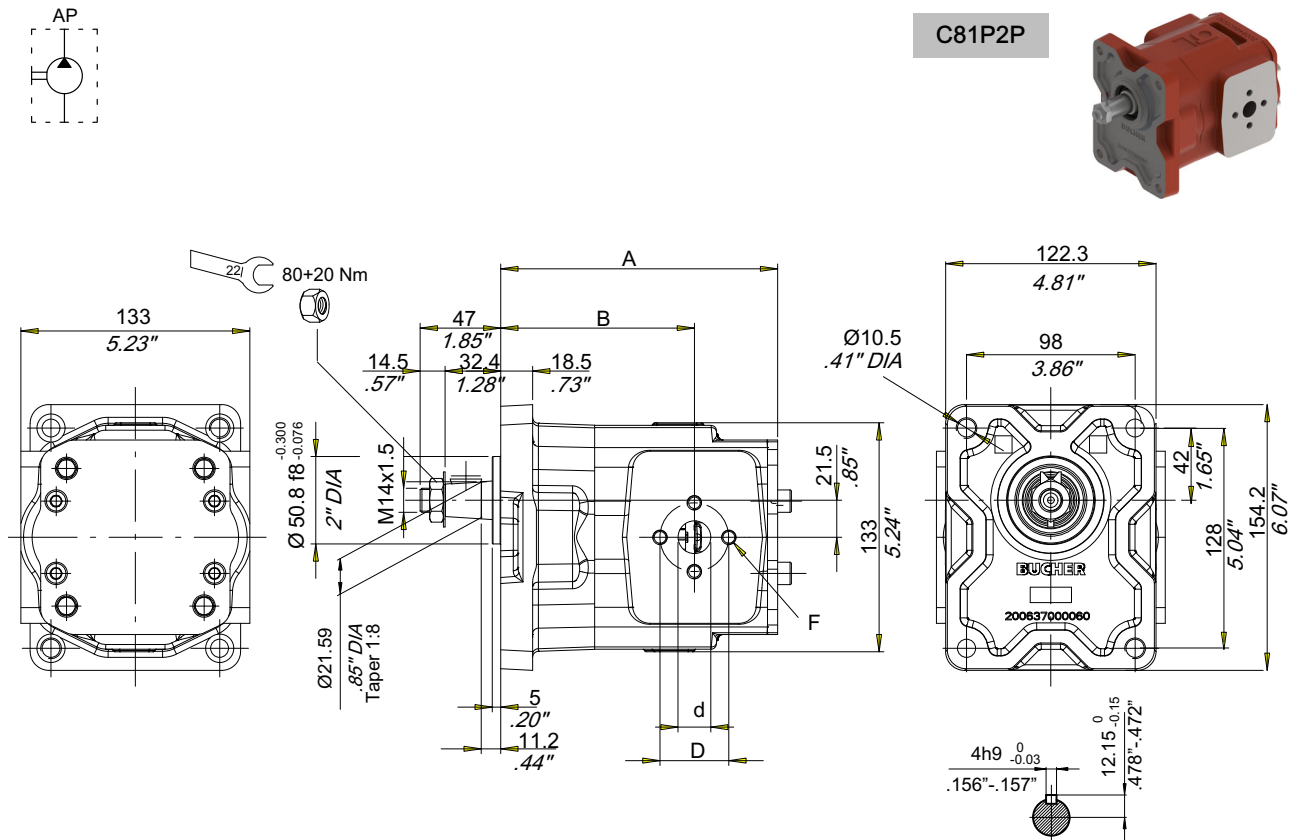

Size	A		B		Suction					Pressure				
	mm	inches	mm	inches	d		D		F	d		D		F
					mm	inches	mm	inches	mm	mm	inches	mm	inches	mm
26	141.5	5.57	98	3.86	19	.75	40	1.57	M8x 1.25	19	.75	40	1.57	M8x 1.25
33	148.5	5.84	105	4.13										
40	156	6.14	107.5	4.23										
45	161	6.34	112.5	4.43										
54	170	6.69	121.5	4.78										
63	181.2	7.13	99.5	3.92	25	.98	51	2.01	M10x 1.5					
75	193.2	7.61	111.5	4.39										
86	193.2	7.61	111.5	4.39	33	1.22	62	2.43	M12x 1.75	27	1.06	51	2.01	M10

63-75-86 displacement under test-phase

Pump description example:

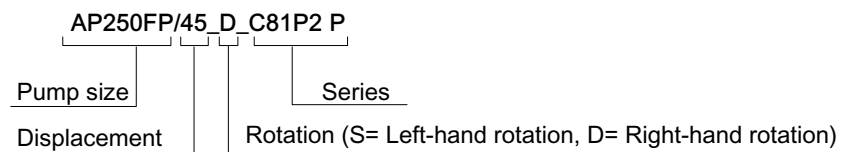

## 2.1.4 European front flange, tapered 1:8, BSP threaded ports

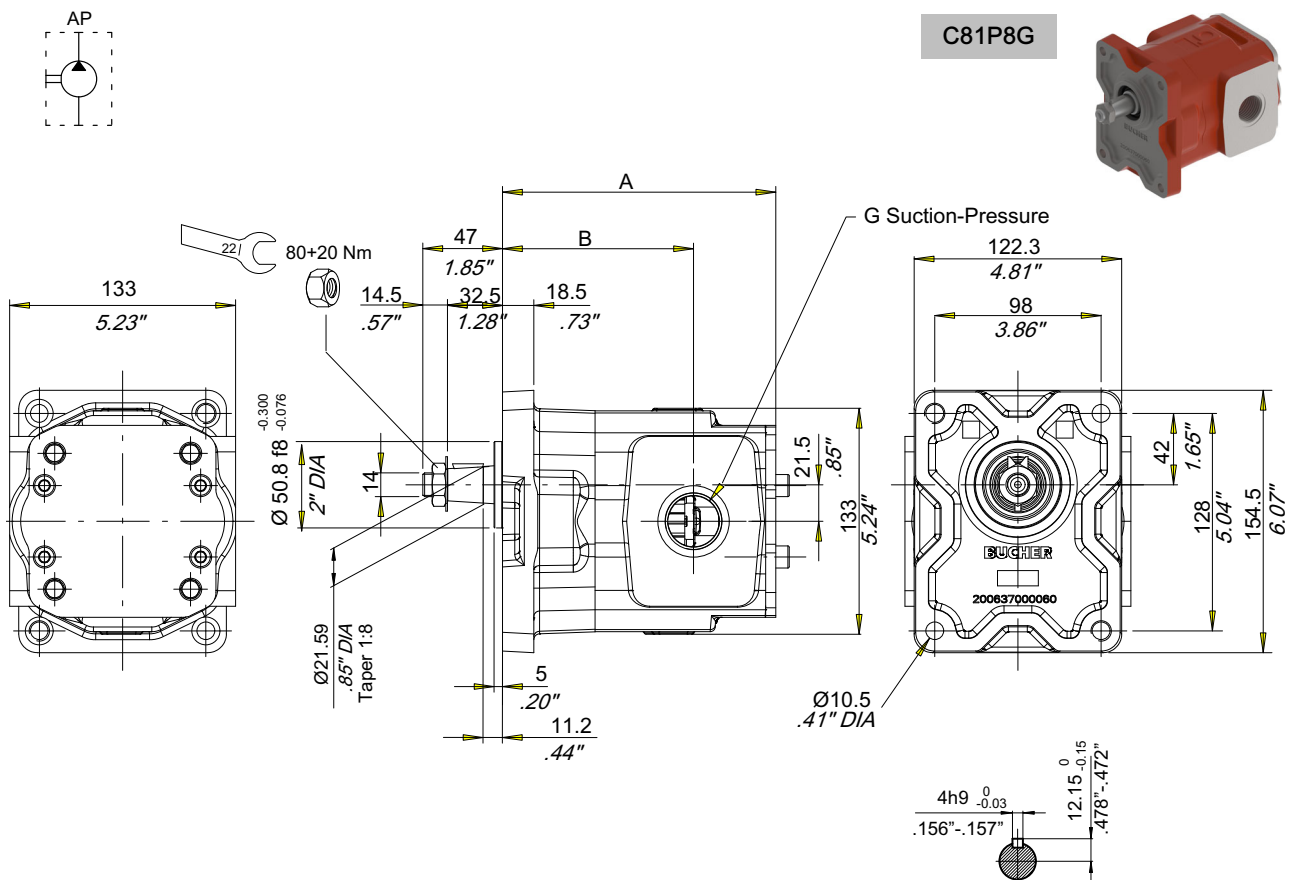

Size	A		B		Suction BSPP	Pressure BSPP
	mm	inches	mm	inches		
26	141.5	5.57	98	3.86	1"	3/4"
33	148.5	5.85	105	4.13		
40	156	6.14	107.5	4.23		
45	161	6.34	112.5	4.43	1" 1/4"	1"
54	170	6.69	121.5	4.78		
63	181.2	7.13	99.5	3.92		
75	193.2	7.61	111.5	4.39		
86	193.2	7.61	111.5	4.39		

63-75-86 displacement under test-phase

Pump description example:

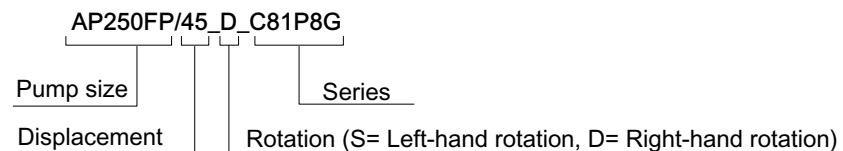

### 3 Rotation changing instructions AP250FP

For the pumps AP250FP with unidirectional left or right rotation, it is possible to change the rotation direction without replacing any component.

In the following pictures, a procedure for the pump rotation inversion is shown. In this example, a clockwise rotation pump (D) is changed into a counter-clockwise rotation (S).

Following instructions are valid for tandem pump AP250FP+AP250FP and tandem pump AP250FP+AP212 too.

**Gear inversion**

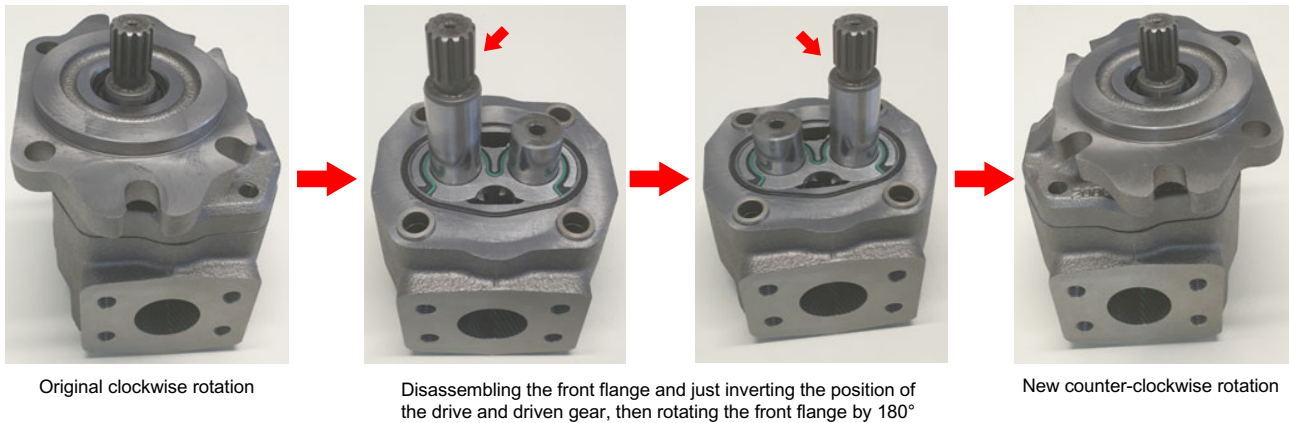

On the front flange the headless screw has to be moved from one side to the other. The use of a heat-gun may be required.

The headless screw must be on the pressure side.

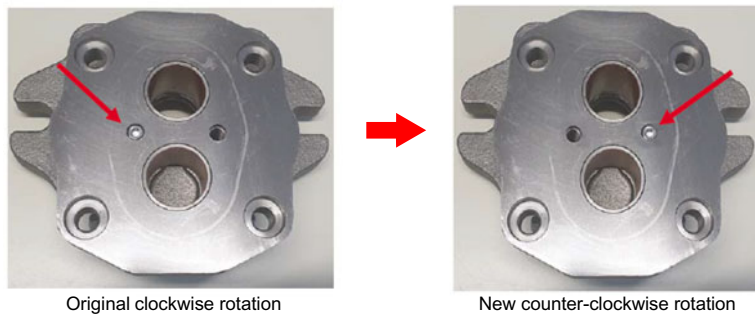

## 4 Multiple gear pumps

### 4.1 Drive torque calculation

#### 4.1.1 Example: AP250FP+AP250FP/AP250HP standard version

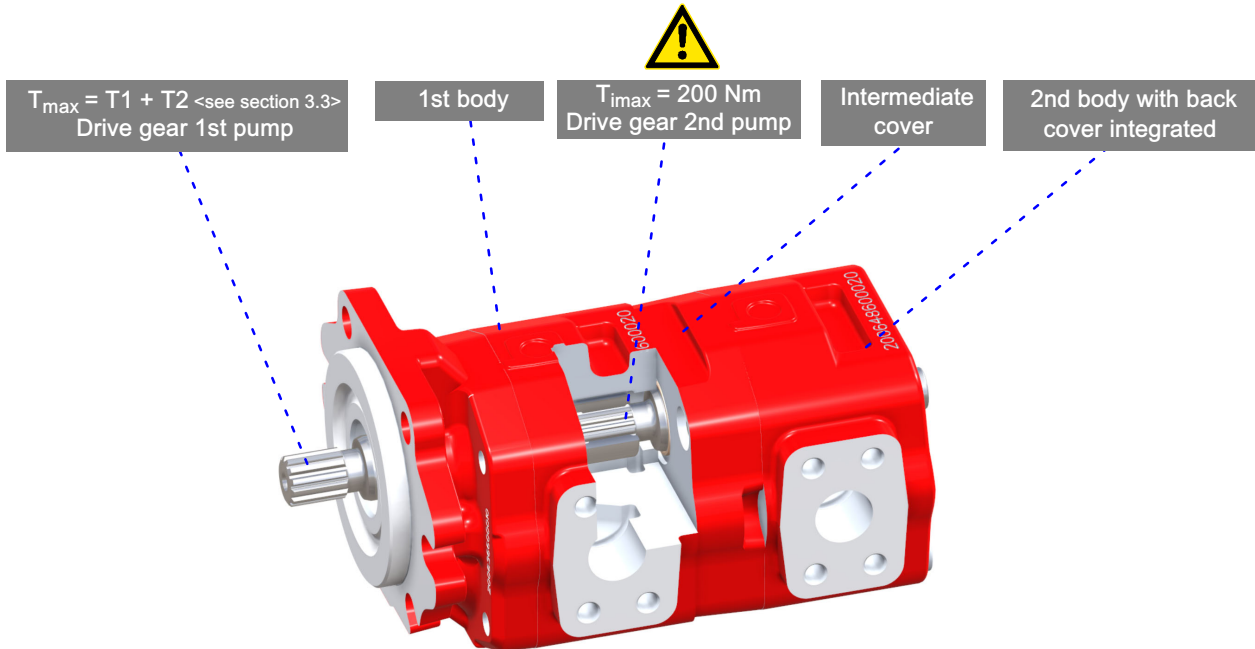

$$T_{max} = 1.59 \cdot \frac{p_1 \cdot V_{c1}}{\eta_{m1}} + 1.59 \cdot \frac{p_2 \cdot V_{c2}}{\eta_{m2}}$$

Example: AP250FP/36 + AP250FP/36

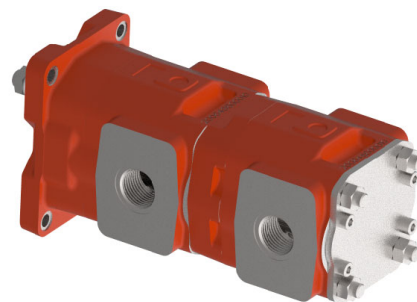
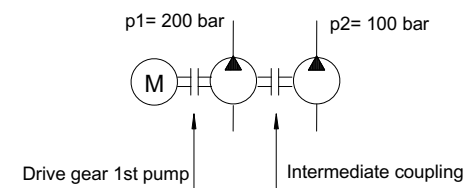

$$T_{max} = 1.59 \cdot \frac{36 \cdot 200}{90} + 1.59 \cdot \frac{36 \cdot 100}{90} = 127.2 + 63.6 = 190.8 \text{ Nm}$$

$$T_{max} = 190.8 \leq 270 \text{ Nm}$$

(splined 13T)

$$T_2 = 63.6 \leq T_{imax} 200 \text{ Nm}$$

## 4.1.2 Example: AP250FP+AP212 standard version



$T_{\max} = T_1 + T_2$  <see section 3.3>  
Drive gear 1st pump

1st body pump  
AP250FP

$T_{\max} = 100 \text{ Nm}$   
Drive gear 2nd pump

2nd body pump  
AP212 (aluminium)

Aluminium or cast iron  
Back cover (available  
also with valves)

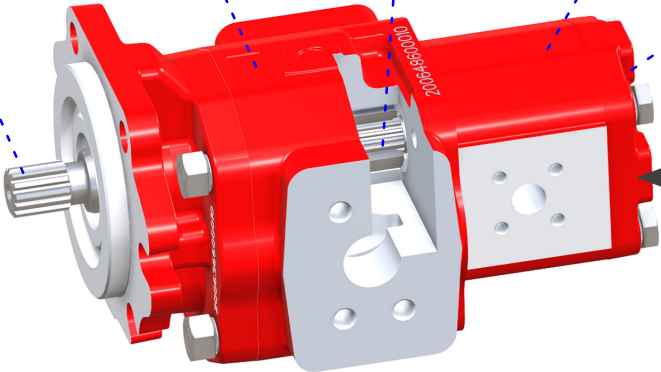

$$T_{\max} = 1.59 \cdot \frac{p_1 \cdot V_{c1}}{\eta_{m1}} + 1.59 \cdot \frac{p_2 \cdot V_{c2}}{\eta_{m2}}$$

### Example: AP250FP/33 + AP212/19

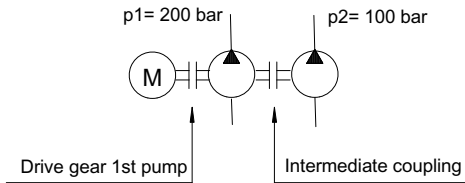

$$T_{\max} = 1.59 \cdot \frac{33 \cdot 200}{90} + 1.59 \cdot \frac{19 \cdot 100}{90} = 116.6 + 33.57 = 150.17 \text{ Nm}$$

$$T_{\max} = 150.17 \leq 270 \text{ Nm (splined 13T)}$$

$$T_2 = 33.57 \leq T_{\max} 200 \text{ Nm}$$

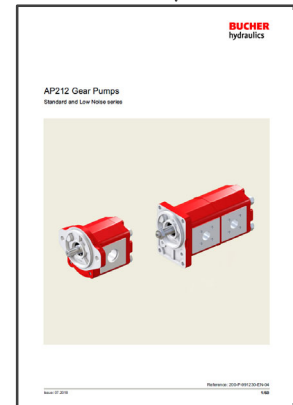

Further information regarding group 2 pumps: see dedicated "AP212 Gear Pumps" catalogue



## 4.2 Multiple version: AP250FP+AP250FP (or AP250HP)

Standard version means separated inlet/outlet side ports, without shaft seal between pump stages.  
There are two possibilities to make a tandem pump of the same series

- 4.2.1 Having on stock the second stage pump AP250FP-MP + the **Kit p/n 200960400840**.  
The rear cover of the first pump must be removed.

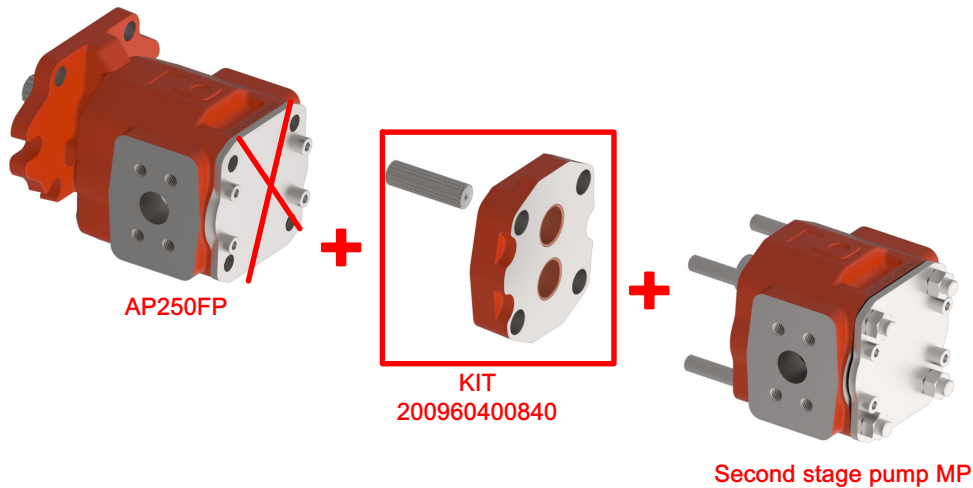

- 4.2.2 Using two first pumps AP250FP + the kit **Kit p/n 200960400840**. The rear cover of the first pump must be removed. In the rear pump the front flange must be removed and the drive shaft needs to be replaced by 2nd pump drive shaft or machined as represented (Fig.1 below).

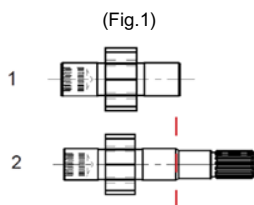
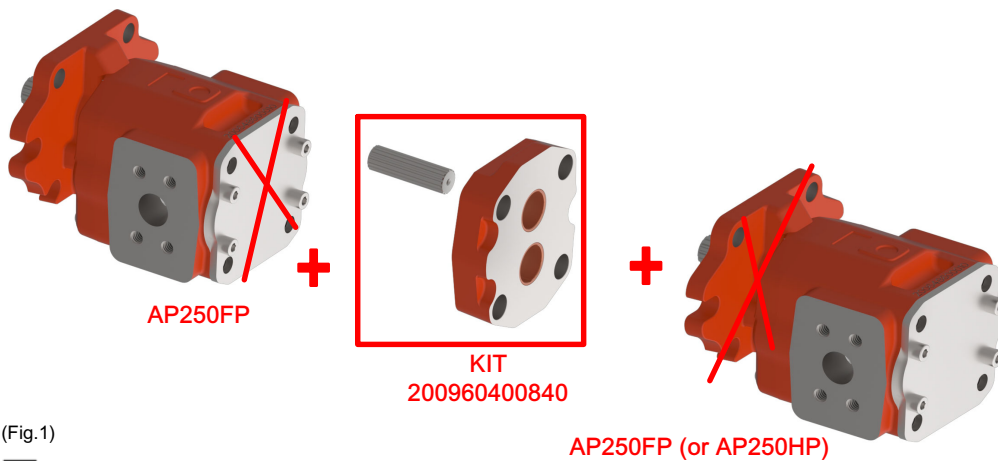

1- Drive shaft for the second pump is available from Bucher Hydraulics.

2- Drive shaft can be obtained by cutting the drive shaft of the second pump.

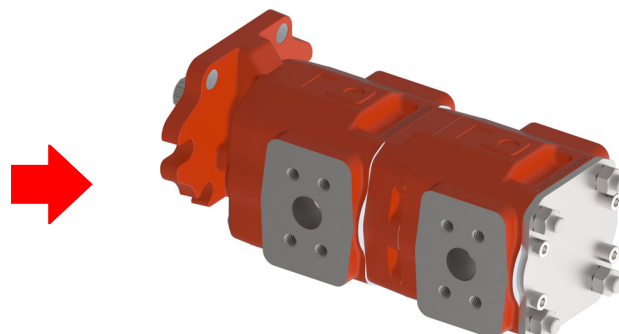

In the next pages, single components and sub-assembly kits are shown; they are necessary to assemble different kinds of multiple pumps.

Please read carefully the important notes related to the assembly phase.

## 4.3 Tandem AP250FP+AP250FP (without shaf seal)

Interface kit AP250FP-AP250FP  
code

200960400840

Interface Kit includes all the necessary components to assemble a tandem AP250FP+AP250FP pump as follow.

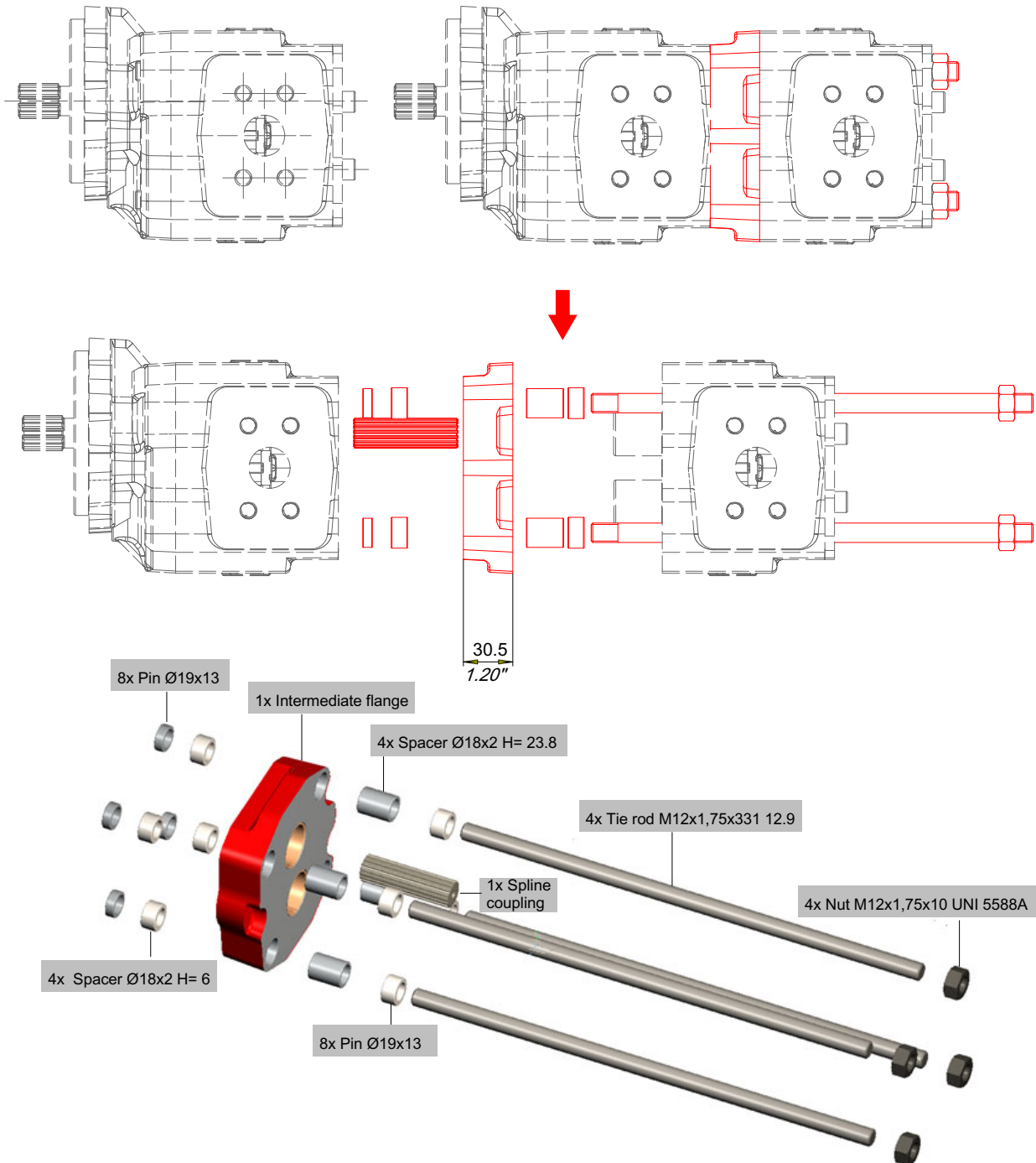

## 4.4 Middle pumps AP250FP-MP dimensions and ordering codes

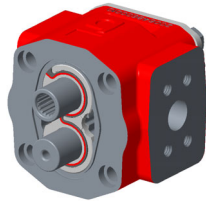
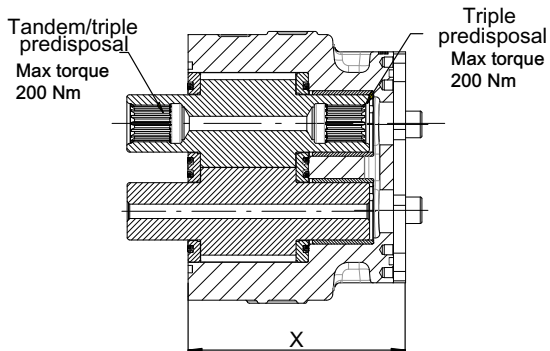

Displacement cm <sup>3</sup> /rev	X	
	mm	inch
26	87	3.43
33	94	1.30
40	101.5	3.99
45	106.5	4.19
54	115.5	4.55
63	125	4.92
75	137	5.39
86	137	5.39

Port type SAE FLANGED PORTS J518 (3000 PSI series)	Dimension (mm - inches)								Description	Ordering code				
	Suction				Pressure									
	H	D	E	F	H	D	E	F						
	30.17	58.72	31.8	M10	26.19	52.37	25.4	M10	AP250FP/26 D 2S-MP	200948930140				
	1.19	2.31	1.25	x1.5					1.03	2.06	1	x1.5	AP250FP/33 D 2S-MP	200948950200
	35.71	69.85	38.1	M12	26.19	52.37	25.4	M10	AP250FP/40 D 2S-MP	200948970140				
	1.14	2.75	1.5	x1.75					1.03	2.06	1	x1.5	AP250FP/45 D 2S-MP	200948980150
														AP250FP/54 D 2S-MP

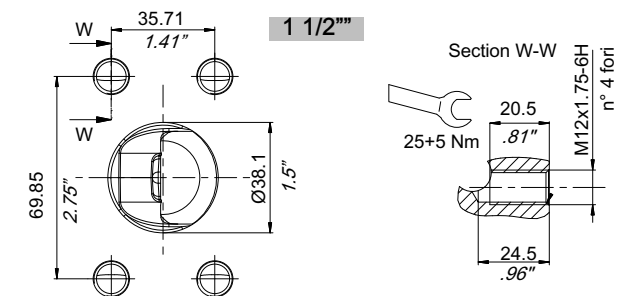
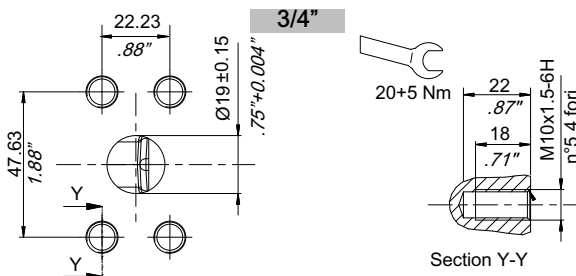
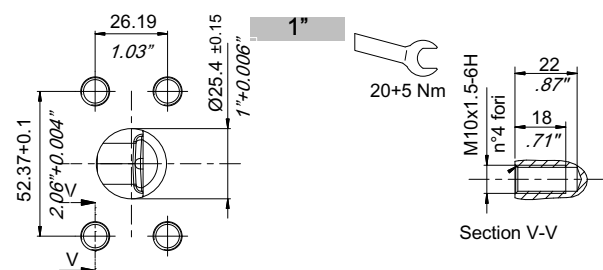
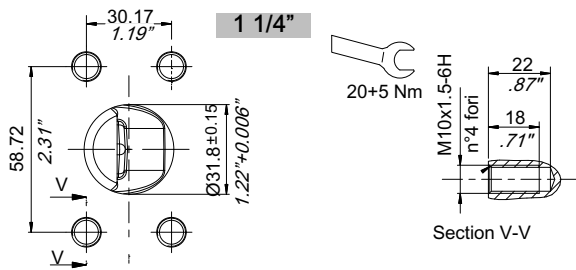

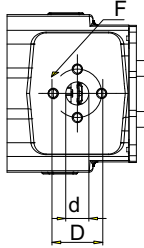
Port type European 4 bolt	Dimension (mm - inches)						Description	Ordering code
	Suction			Pressure				
	d	D	F	d	D	F		
	19 .75	40 1.57	M8x1.25	19 .75	40 1.57	M8x1.25	AP250FP/26 D 2P-MP	200948930160
							AP250FP/33 D 2P-MP	200948930170
							AP250FP/40 D 2P-MP	200948930180
	25 .98	51 2.01	M10x1.5	19 .75	40 1.57	M8x1.25	AP250FP/45 D 2P-MP	200948930190
							AP250FP/54 D 2P-MP	200948930200

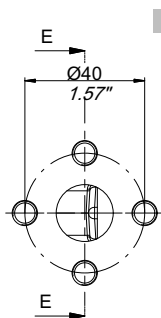

2PA

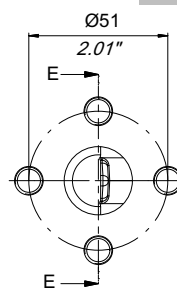
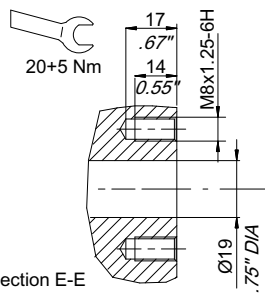

2PB

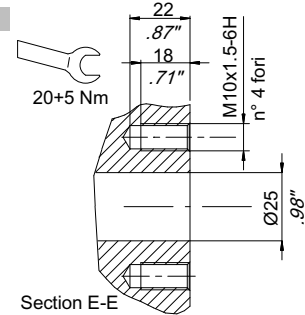

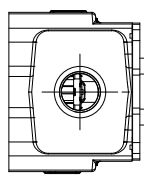
Port type BSP Ports	Dimension (mm - inches)		Description	Ordering code
	Suction	Pressure		
	1" BSP	3/4" BSP	AP250FP/26 D 8G-MP	200948930150
			AP250FP/33 D 8G-MP	200948950210
	1 1/4" BSP	1" BSP	AP250FP/40 D 8G-MP	200948970150
			AP250FP/45 D 8G-MP	200948980160
			AP250FP/54 D 8G-MP	200948990020

3/4" BSP

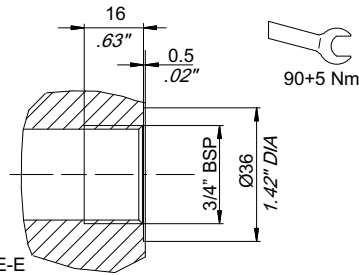
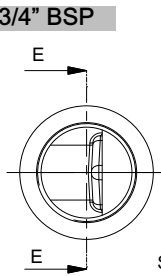

1" BSP

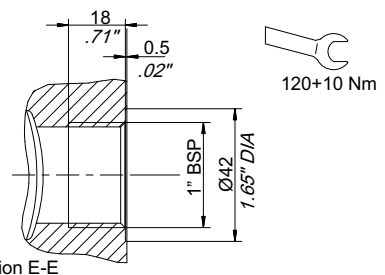
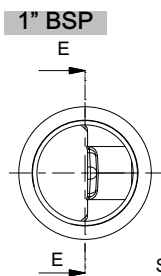

1 1/4" BSP

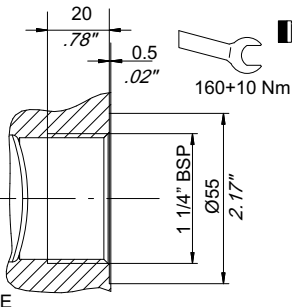
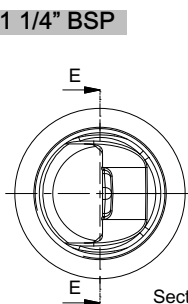

**IMPORTANT!** Tightening torques depends on several different factors including lubrication, coating and surfaces finish. The fitting manufacturer shall be consulted. In the interest of safety, only fittings with STRAIGHT THREAD ENDS should be used (e.g. DIN3852). Fittings with TAPERED THREAD ENDS (e.g. DIN 3852 form C) should never be used, as they can cause deformation and cracks in the pump body. Our warranty conditions will not be valid in case tapered fittings are used. The work port adaptors have to be fastened respecting the indicated tightening torque values.

4.4.1 Tie-rods: cutting instructions

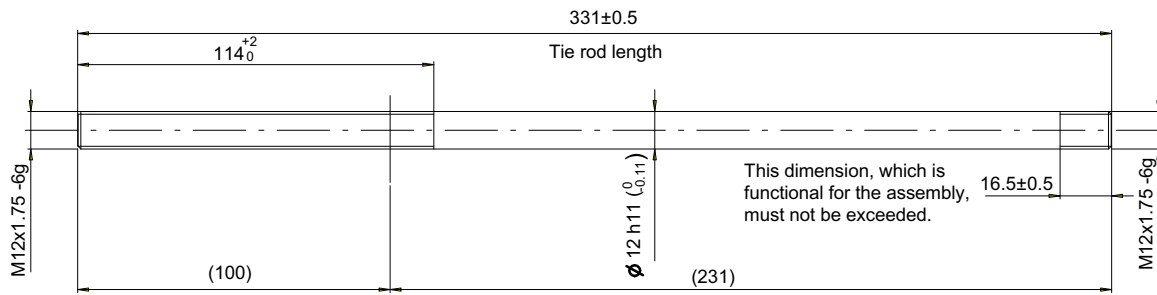

Length to cut a tie rod for an AP250FP/26+AP250FP/26

AP250FP	/26	/33	/40	/45	/54	/63	/75	/86
AP250FP/26	231 / 9.09"	238 / 9.37"	245.5 / 9.67"	250.5 / 9.86"	259.5 / 10.22"	269 / 10.59"	281 / 11.06"	281 / 11.06"
AP250FP/33	238 / 9.37"	245 / 9.65"	252.5 / 9.94"	257.5 / 10.14"	266.5 / 10.49"	276 / 10.87"	288 / 11.34"	288 / 11.34"
AP250FP/40	245.5 / 9.67"	252.5 / 9.94"	260 / 10.23"	265 / 10.43"	274 / 10.79"	283.5 / 11.16"	295.5 / 11.63"	295.5 / 11.63"
AP250FP/45	250.5 / 9.86"	257.5 / 10.14"	265 / 10.43"	270 / 10.63"	279 / 10.98"	288.5 / 11.36"	300.5 / 11.83"	300.5 / 11.83"
AP250FP/54	259.5 / 10.22"	266.5 / 10.49"	274 / 10.79"	279 / 10.98"	288 / 11.34"	297.5 / 11.71"	309.5 / 12.19"	309.5 / 12.19"
AP250FP/63	269 / 10.59"	276 / 10.87"	283.5 / 11.16"	288.5 / 11.36"	297.5 / 11.71"	307 / 12.09"	319 / 12.56"	319 / 12.56"
AP250FP/75	281 / 11.06"	288 / 11.34"	295.5 / 11.63"	300.5 / 11.83"	309.5 / 12.19"	319 / 12.56"	331 / 13.03"	331 / 13.03"
AP250FP/86	281 / 11.06"	288 / 11.34"	295.5 / 11.63"	300.5 / 11.83"	309.5 / 12.19"	319 / 12.56"	331 / 13.03"	331 / 13.03"

## 4.5 Multiple versions: AP250FP+AP212-MPS (or AP212HP-MPS)

How to manage the assembly for multiple pumps with AP250FP and AP212 (or AP212HP)

1. It is necessary to have in stock the AP212-MPS stage, the rear cover, the [Kit p/n 200960400850](#) and 4x bolts. The length of the bolts depends on the pump displacement and type of rear cover.

Interface kit AP250FP-AP212-MPS code
---

200960400850

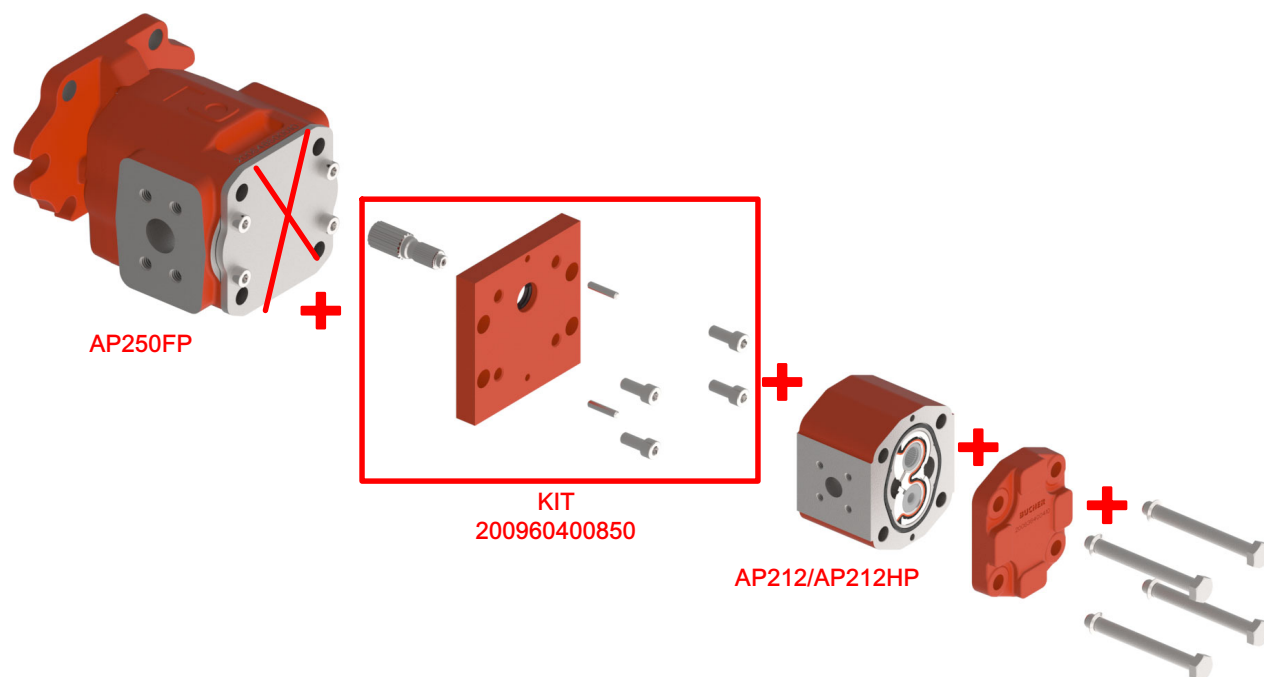

#### 4.6 Tandem AP250FP+AP212 or AP212HP (with shaf seal)

Interface kit AP250FP-AP212/AP212HP  
code

200960400850

Interface Kit includes all the necessary components to transform a single AP250FP to a multiple AP250FP+AP212 or AP250FP+AP212HP pump as follow.

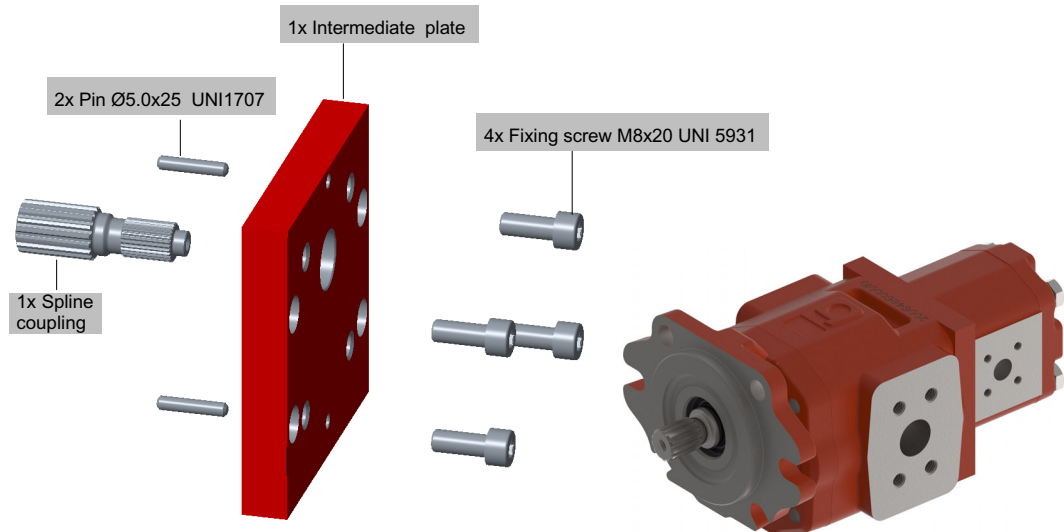
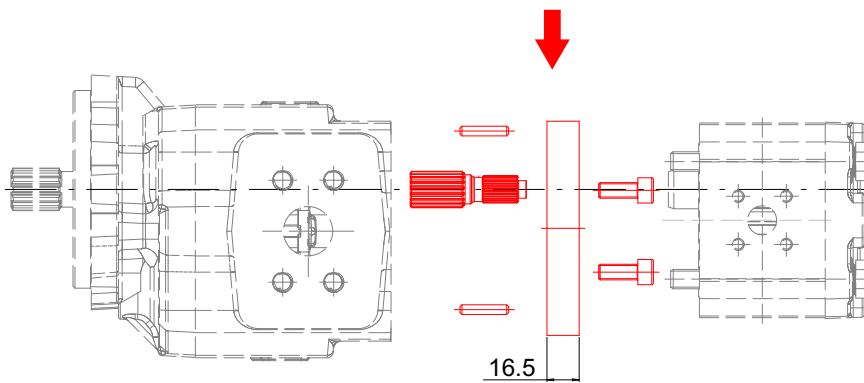
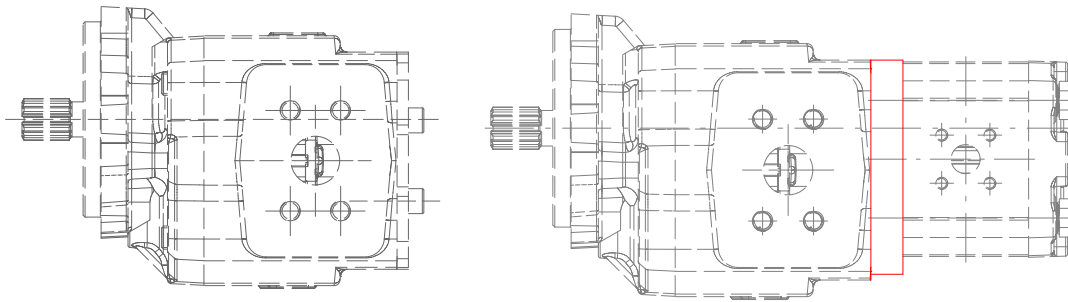

## 4.7 Mid pump AP212-MPS: dimensions and ordering codes

### 4.7.1 AP212 With shaft seal

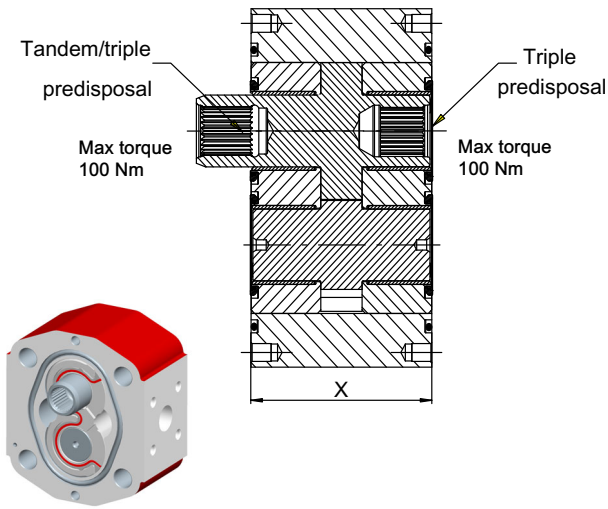

Displacement cm <sup>3</sup> /rev	X	
	mm	inch
4.5	48.6	1.91
6.5	51.6	2.03
8.5	54.6	2.15
11	58.6	2.31
15	64.6	2.54
19	70.6	2.78
22	75	2.95
26	81	3.19

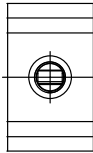
Port type BSPP threaded ports	Suction	Pressure	Description*	Ordering code (with shaft seal)
	3/8"	3/8"	AP212/4,5 D 4A-MPS	200948910130
	3/8"	3/8"	AP212/6,5 D 4A-MPS	200948910140
	3/8"	3/8"	AP212/8,5 D 4A-MPS	200948910150
	1/2"	3/8"	AP212/11 D 4B-MPS	200948910160
	1/2"	3/8"	AP212/15 D 4B-MPS	200948910170
	3/4"	1/2"	AP212/19 D 4C-MPS	200948910180
	3/4"	1/2"	AP212/22 D 4C-MPS	200948910190
	3/4"	1/2"	AP212/26 D 4C-MPS	200948910200

At pressure P2 > 210 bar limited service life

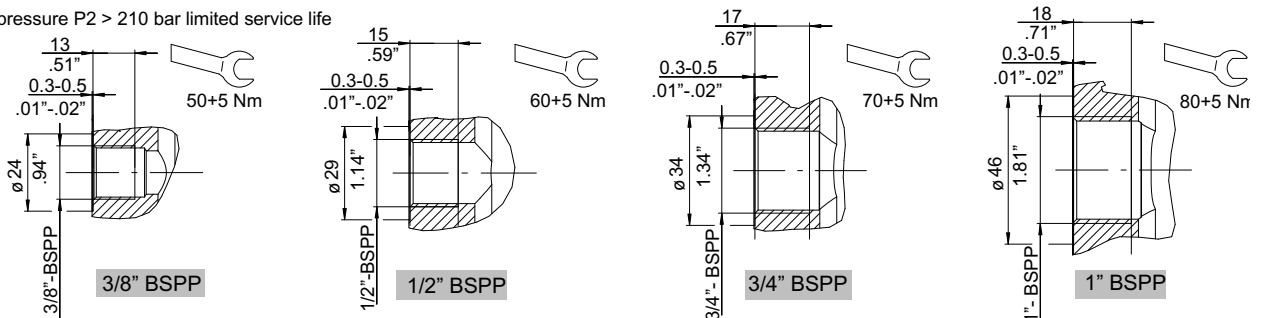

\* Clockwise rotation codes only. It is possible to change the rotation directions, see the instructions in section 4.10

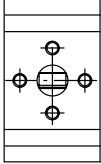

Port type European 4 bolt	Suction	Pressure	Description*	Ordering code (with shaft seal)
	13.5 - .53 (d) 30 - 1.18 (D) M6 (F)	13.5 - .53 (d) 30 - 1.18 (D) M6 (F)	AP212/4,5 D 3A-MPS	200948910260
			AP212/6,5 D 3A-MPS	200948920140
			AP212/8,5 D 3A-MPS	200948930210
	19 - .75 (d) 40 - 1.58 (D) M8 (F)	13.5 - .53 (d) 30 - 1.18 (D) M6 (F)	AP212/11 D 3B-MPS	200948940140
			AP212/15 D 3B-MPS	200948950240
	19 - .75 (d) 40 - 1.58 (D) M8 (F)	19 - .75 (d) 40 - 1.58 (D) M8 (F)	AP212/19 D 3C-MPS	200948960140
			AP212/22 D 3C-MPS	200948970160
			AP212/26 D 3C-MPS	200948980170

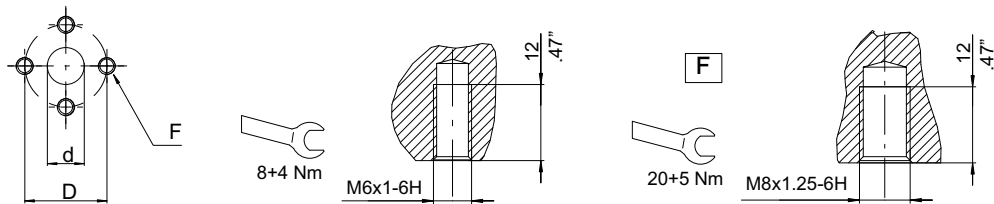

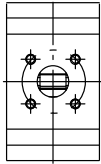
Port type German 4 bolt flanged (** for 287S-SAEB, only)	Suction	Pressure	Description*	Ordering code (with shaft seal)	
	15 - .59 (d) 40 - 1.58 (D) M6 (F)	15 - .59 (d) 35 - 1.38 (D) M6 (F)	AP212/4,5 D 2A-MPS	200948910270	
			AP212/6,5 D 2A-MPS	200948920150	
			AP212/8,5 D 2A-MPS	200948930220	
	20 - .79 (d) 40 - 1.58 (D) M6 (F)		AP212/11 D 2B-MPS	200948940150	
			AP212/15 D 2B-MPS	200948950250	
			AP212/19 D 2B-MPS	200948960180	
			AP212/22 D 2B-MPS	200948970200	
	** 24 - .95 (d) 55 - 2.17 (D) M8 (F)		** 15 - .59 (d) 35 - 1.38 (D) M5 (F)	AP212/26 D 2B-MPS	200948980230
				AP212/219 D 2C-MPS	200948960150
				AP212/22 D 2C-MPS	200948970170
				AP212/26 D 2C-MPS	200948980180

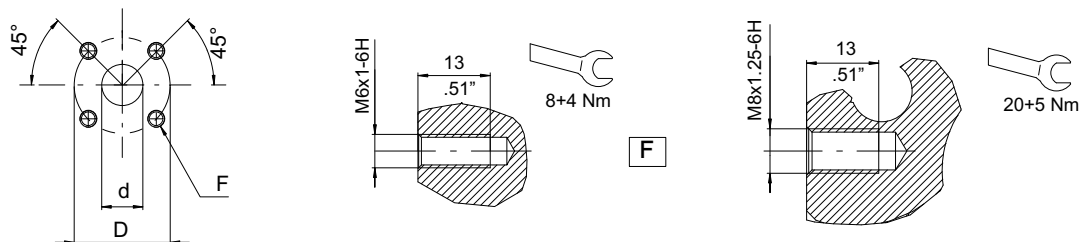

\* Clockwise rotation codes only. It is possible to change the rotation directions, see the instructions in section 4.10

## 4.7.2 Mid pump AP212HP: dimensions and ordering codes

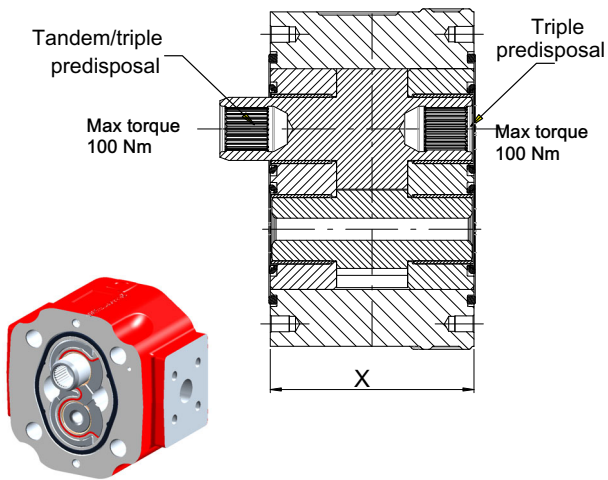

Displacement cm <sup>3</sup> /rev	X	
	mm	inch
15	64.6	2.54
19	70.6	2.78
22	75	2.95
26	81	3.19
29	85.1	3.35
33	91.1	3.59

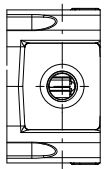
Port type Threaded ports	Dimension (mm - inch)		Description*	Ordering code
	Suction	Pressure		
	1/2"	3/8"	AP212HP/15 D 4B-MPS	200948910210
	3/4"	1/2"	AP212HP/19 D 4C-MPS	200948910220
	3/4"	1/2"	AP212HP/22 D 4C-MS	200948910230
	3/4"	1/2"	AP212HP/26 D 4C-MPS	200948910240
	1"	1/2"	AP212HP/29 D 4D-MPS	200948910250
	1"	1/2"	AP212HP/33 D 4D-MPS	200948990050

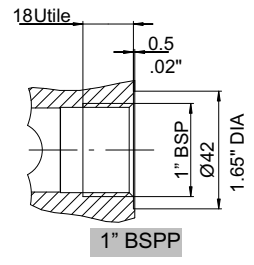
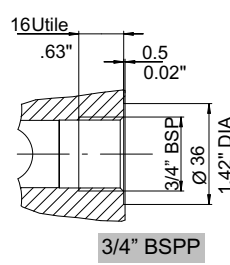
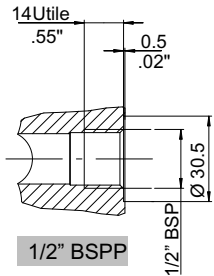
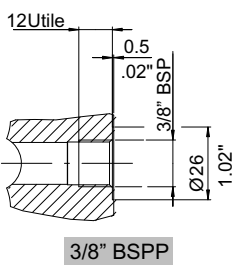

### Recommended tightening torque for work port fittings - Nm / lbf

BSPP - ISO 228-1	3/8" BSPP	1/2" BSPP	3/4" BSPP	1" BSPP
With copper washer (ISO 1179-1)	40 / 29.5 (±10%)	60 / 44.3 (±10%)	90 / 66.4 (±10%)	100 / 73.8 (±10%)
With rubber washer or steel (ISO 1179-1)	35 / 25.8 (±10%)	60 / 44.3 (±10%)	70 / 51.7 (±10%)	90 / 66.4 (±10%)

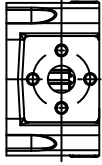
Port type European 4 bolt	Dimension (mm - inch)		Ordering code	Ordering code
	Suction	Pressure		
	19 - .75 (d) 40 - 1.58 (D) M8 (F)	13.5 - .53 (d) 30 - 1.18 (D) M6 (F)	AP212HP/15 D 3B-MPS	200948950260
		19 - .75 (d) 40 - 1.58 (D) M8 (F)	AP212HP/19 D 3C-MPS	200948960160
	AP212HP/22 D 3C-MPS		200948970180	
	AP212HP/26 D 3C-MPS		200948980190	
	AP212HP/29 D 3C-MPS		200948980200	
			AP212HP/33 D 3C-MPS	200948990030

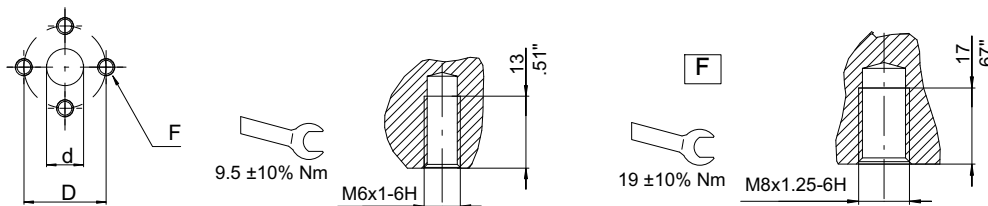

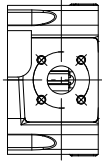
Type German 4 bolt flanged	Dimension (mm - inch)		Description*	Ordering code
	Suction	Pressure		
	20 - .79 (d) 40 - 1.58 (D) M6 (F)	15 - .59 (d) 35 - 1.38 (D) M6 (F)	AP212HP/15 D 2B-MPS	200948950270
			AP212HP/19 D 2B-MPS	200948960170
			AP212HP/22 D 2B-MPS	200948970190
	24 - .95 (d) 55 - 2.17 (D) M8 (F) (287-S SAEB)		AP212HP/26 D 2B-MPS	200948980210
			AP212HP/29 D 2C-MPS	200948980220
			AP212HP/33 D 2C-MPS	200948990040

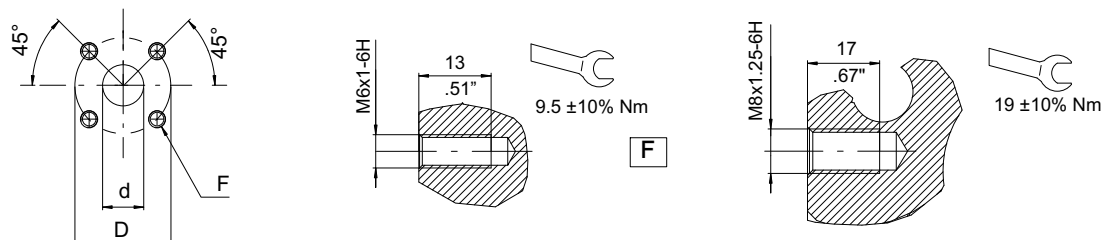

## 4.8 Bolts

To combine AP250-FP + AP212-MPS  
see AP212 standard end cover

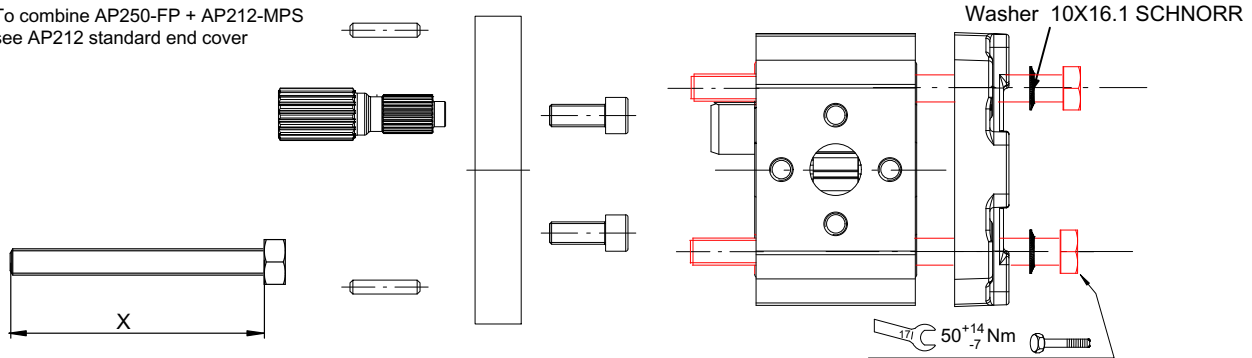

Single pump		
Serie	Displacement	Length (mm)
218 818	4,5	80
	6,5	80
	8,5	85
	11	90
	15	95
	19	100
	22	105
	26	110



### Attention:

In order to tight the bolts correctly, please be sure to use high quality steel bolts (such as 10.9 UNI5737) and to respect the suggested torque value.

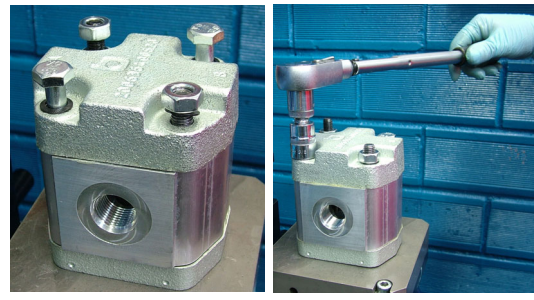

The length of the bolts depends on the pump displacement as well as the pump series (front and rear covers). Please consult our Sales Centre.

## 4.9 Back covers

### 4.9.1 Cast iron back cover - Standard version for unidirectional pump

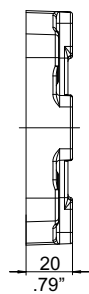
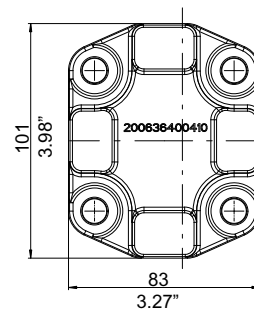
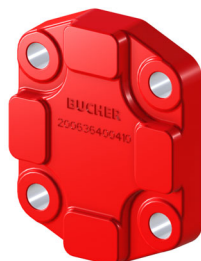
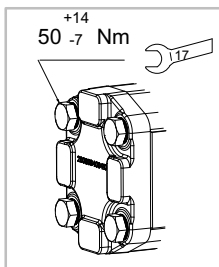

Type	Description	Ordering code
Back cover, standard version, cast iron material	GH	200636400421

## 4.9.2 Cast iron back cover with relief valve VI

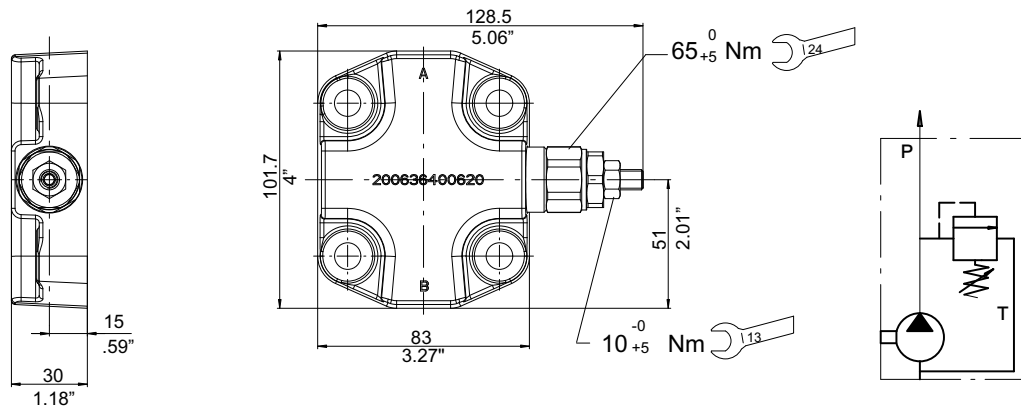

A P 2 1 2 / 8 . 5 - S - A 1 S - 1 C - V I \* \* - A

Type	Ordering code
Cast iron back cover with relief valve. Return to internal pump suction	VI**

\*\* pressure set value (bar) - in example: VI15 = 150 bar



Attention: Please take care that when the relief valve open, oil temperature increase quickly. These conditions have effect in the pump performances and life

## 4.9.3 Cast iron back cover with relief valve VE

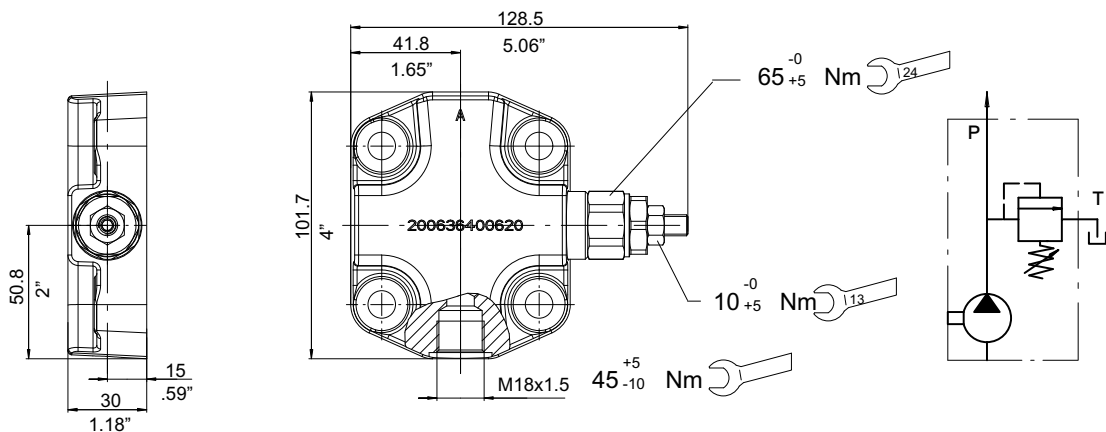

A P 2 1 2 / 8 . 5 - S - A 1 S - 1 C - V E \* \* - A

Type	Ordering code
Cast iron back cover with relief valve. Return to external pump tank	VE**

\*\* pressure set value (bar) - in example: VE06 = 60 bar

## 4.9.4 Pressure relief valve : \*\*VM01C VI\*\* and VE\*\* pressure setting range

Direct acting  
Balanced piston  
Adjustable setting  
Four setting ranges

Max. Pressure ..... 350 bar \*\*\*  
Max flow rate ..... 60 l/min.  
Temperature range ..... -20/+100 °C  
Weight: ..... 0.155 Kg.

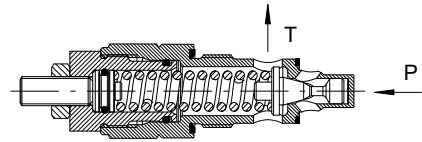
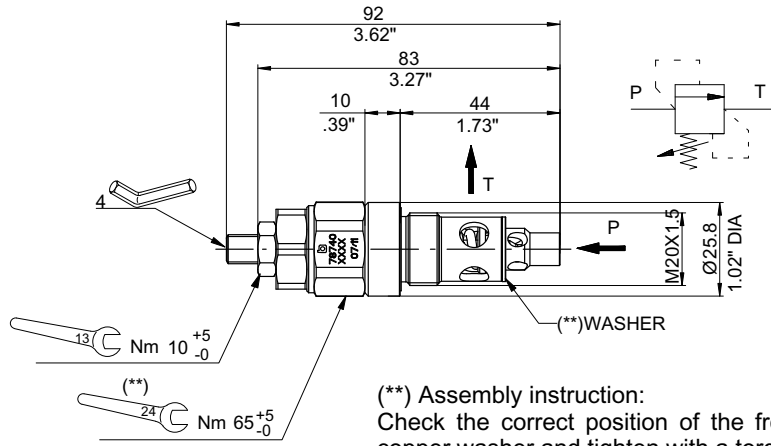

The valve can be sealed against tampering

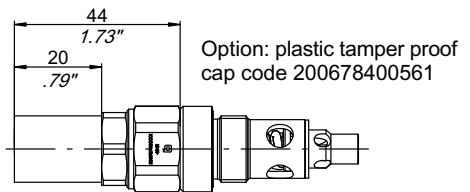

(\*\*) Assembly instruction:  
Check the correct position of the front copper washer and tighten with a torque wrench at the indicated value

Pressure viscosity characteristic 46 cSt at 40°C

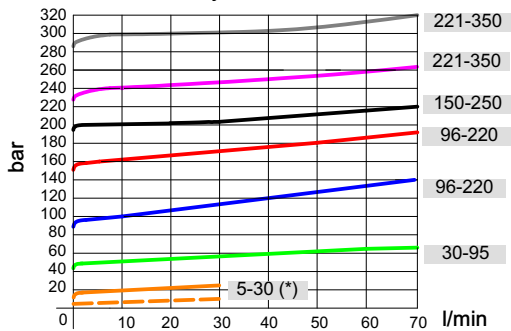

(\*) see performances trace/minimum pressure setting (---)

The purpose of a relief valve is to keep the maximum system pressure at a safe level. When the external gear pump is supplied with pressure relief valves, the correct calibration is provided by Bucher Hydraulics S.p.A. and there are no reasons to change this value. When ordering, state in full the sheath part number, and, if the valve is to be supplied with sheath already fitted, the relief pressure setting required.

\*\*\* Maximum admitted pressure value: referred to valve only. For max admitted values see pump limits.

Performances	
Max. flow	60 l/min.
Pressure setting flow	5 l/min
Max internal leakage	200 cm <sup>3</sup> /min at 80% of nominal pressure setting
Oil viscosity	12 to 400 cSt
Oil temperature	-20 to 100 °C
Recommended filtration	21/19/16 (10 NAS 1638)
Marking info:	Printed code and date

Spring	Spring code	Setting range	Standard setting	Q max (l/min)	Type	Relief valve only code
00	-	Plugged	Without valve	-	00VC00	200978400140
02	200662403160	5 - 30 bar	20 bar	30 (*)	02VM01C	200787403600
05	200662403080	30 - 95 bar	50 bar	60	05VM01C	200787403480
12	200662403050	96 - 220 bar	120 bar	60	12VM01C	200787403420
15	200662403070	150 - 250 bar	150 bar	60	15VM01C	200787403470
23	200662403060	221 - 350 bar	230 bar	60	23VM01C	200787403430

Pressure setting valve referred to 5 l/min

#### 4.10 Rotation changing instructions AP212

For the intermediate body Kit tandem/triple predisposal AP212 - AP212HP (or AP250FP pumps) with unidirectional left or right rotation, it is possible to change the rotation direction of the entire range without having to replace any component.

To ensure a good technical result, we recommend to operate in very clean ambient.

This operation must be performed by a skilled worker. In the following pictures, a procedure for the pump rotation inversion is shown (in this example, a counter-clockwise rotation pump S is changed into a clockwise-rotation one D).

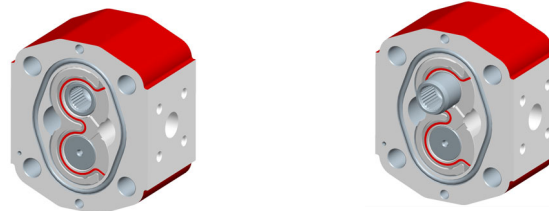

Initial configuration "Left" (S)

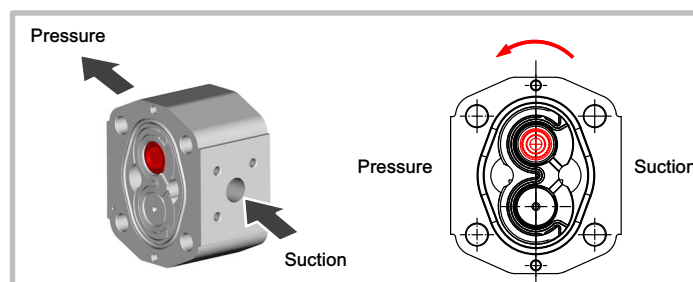

Picture -1-

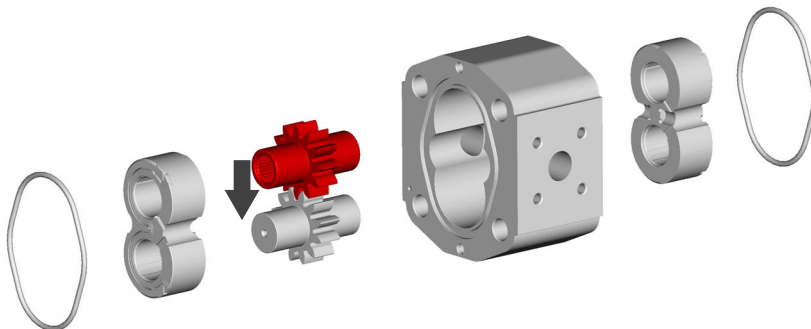

Picture -2-

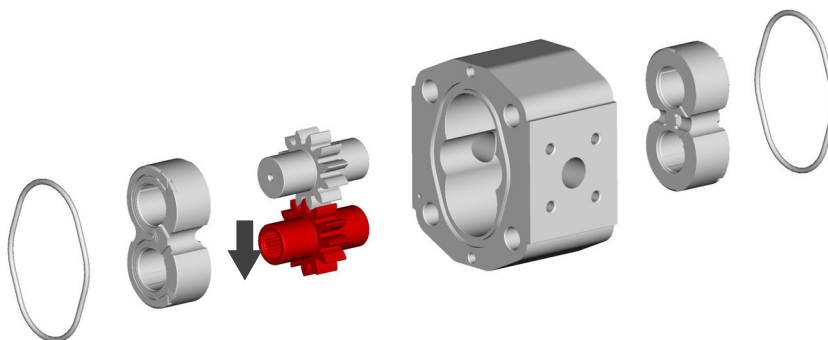

Final configuration "Right" (D)

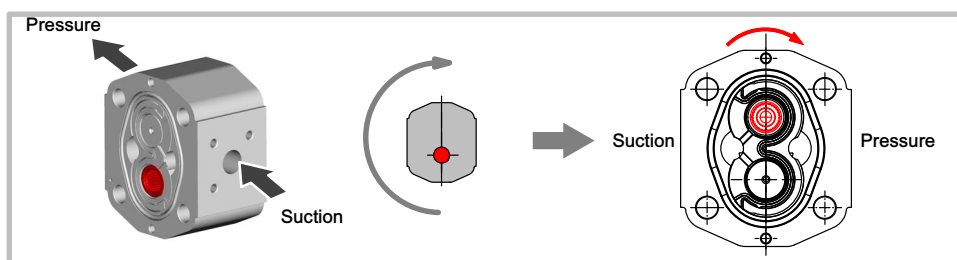

### 4.11 Warnings



Attention:

1- During the assembly phase, pay attention to the correct body seals position.  
 Help yourself using grease, to avoid the wrong positioning of the seals.  
 The grease helps to maintain the seal in the correct position.  
 Do not exceed with grease quantity; it might be pushed out of the body during the first operating working hours (especially when the oil is hot).

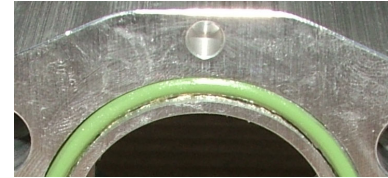
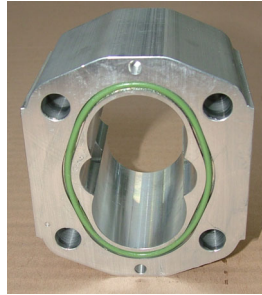

2- Pay attention to the maximum admitted torque, especially in presence of tandem or triple pumps.  
 The max. admitted torque value does not depend only on gear shaft limits but also on the pump pressure limits.

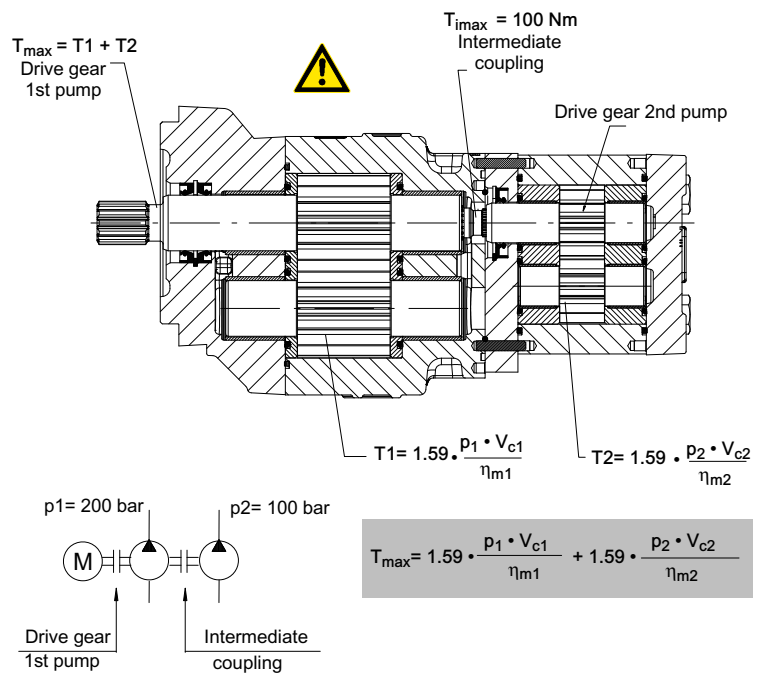

Example: AP250FP/45 + AP212/11

$$T_{\max} = 1.59 \cdot \frac{45 \cdot 200}{90} + 1.59 \cdot \frac{11.1 \cdot 100}{90} = 159 + 19.61 = 178.61 \text{ Nm}$$

$$T_{\max} = 178.61 \leq 270 \text{ Nm (SAE 13T-S3)} \quad T_2 = 19.61 \leq M_{i\max} 100 \text{ Nm}$$



## 5 Pumps seal kit NBR standard type

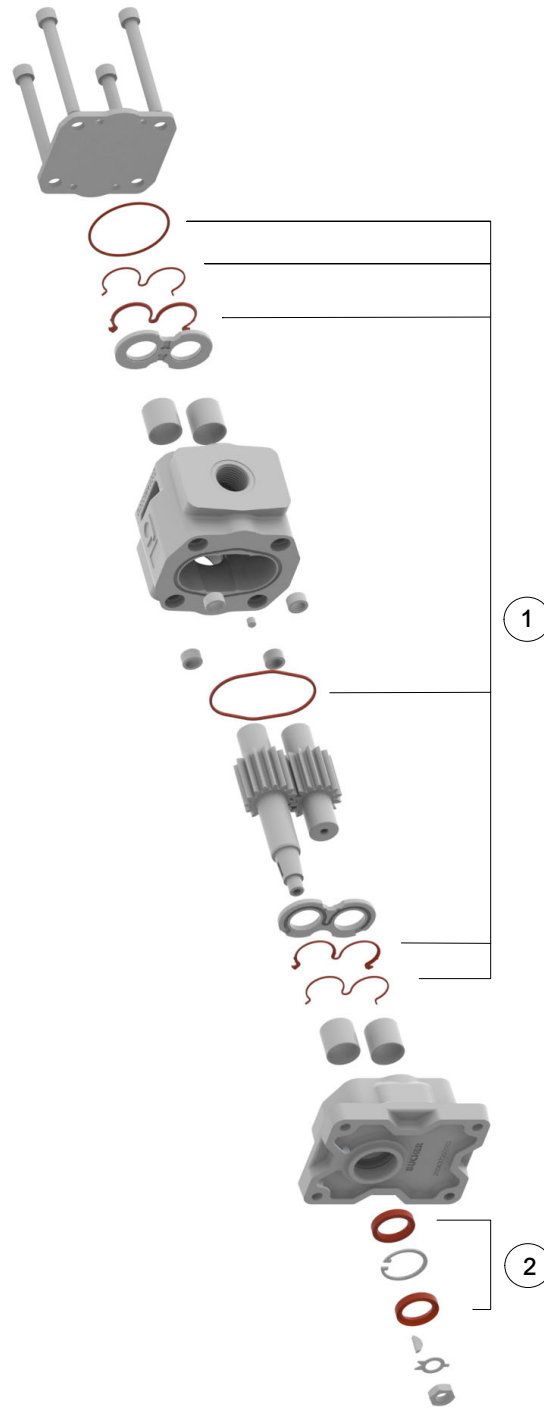

1) -> SEAL KIT = KIT GUARN.AP250FP PAR+OR code 200974200540

2) -> SEAL = PAR WA 28X40X7 HNBR 2 x code 200511214055

